

# Shapeoko 5 Pro Assembly Manual

2024-1-19

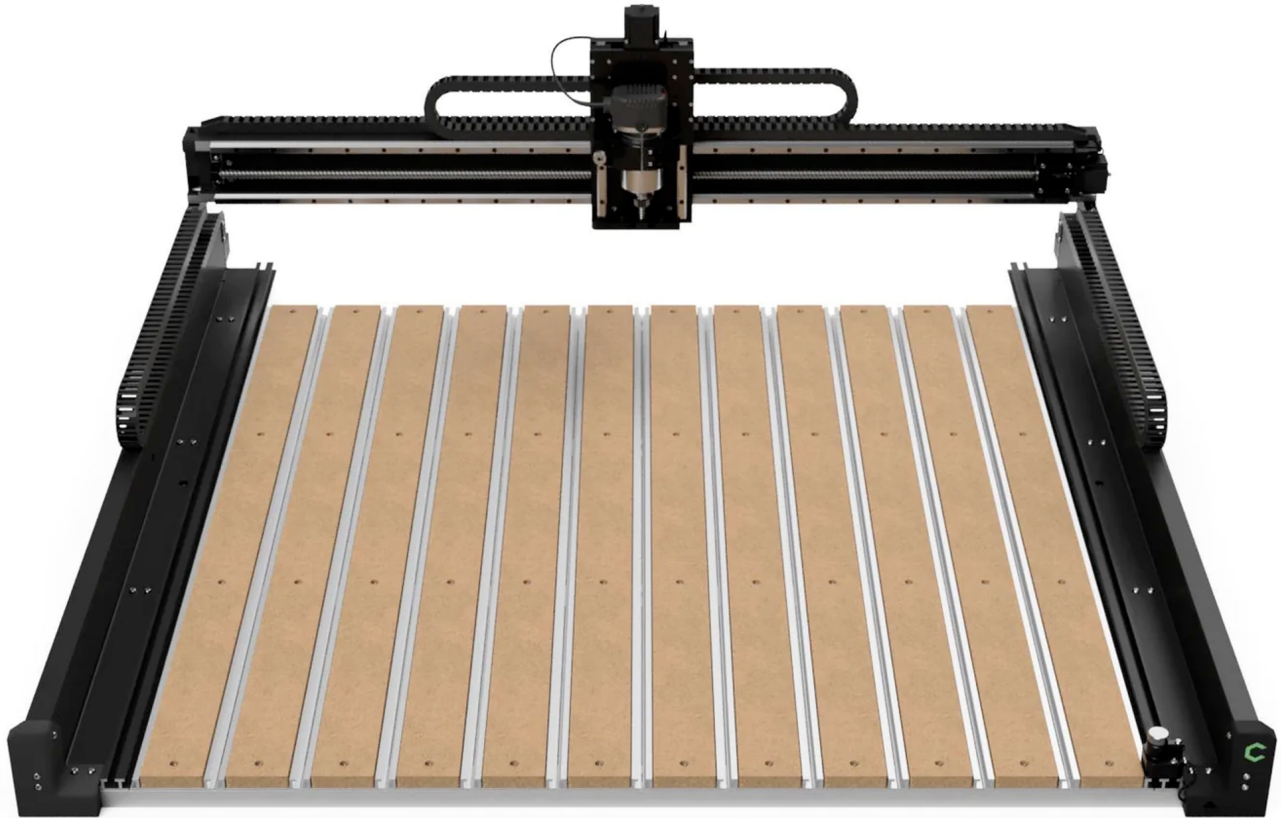



# Before You Start



Visit the Shapeoko 5 Pro Getting Started page to check for updates to this manual

<https://my.carbide3d.com/gettingstarted/shapeoko5pro/>



Watch a quick video overview of the assembly process

<https://qr.carbide3d.com/unboxing/s5>

# Table of Contents

<b>1. Welcome and Congratulations</b>	<b>p. 6</b>
1.1 Assembly Notes	p. 6
1.2 Technical Support	p. 6
1.3 Shipping Box 1 Inventory	p. 7
1.4 Shipping Box 2 Inventory	p. 9
<b>2. Baseframe and Gantry</b>	<b>p. 11</b>
2.1 Unpack Shipping Box 1	p. 11
2.2 Position Baseframe	p. 12
2.3 Install Y-Right Assembly	p. 12
2.4 Install Y-Left Assembly	p. 14
2.5 Install the Cable Track	p. 16
2.6 Prepare for Gantry Install	p. 17
2.7 Open Shipping Box 2	p. 17
2.8 Install Gantry Assembly	p. 18
2.9 Square the Machine	p. 21
<b>3. HDZ (Z-Axis)</b>	<b>p. 22</b>
3.1 Install the HDZ	p. 22
3.2 Connect Z-Axis Cables	p. 24
3.3 Install X-Axis Stepper Motor	p. 24
<b>4. Hybrid Table</b>	<b>p. 27</b>
4.1 Install Extrusions	p. 28
4.2 Install MDF Strips	p. 29
<b>5. Wiring Harness</b>	<b>p. 30</b>
5.1 Install Wiring Harness	p. 32
5.2 Install YL Wire Keeper	p. 33
5.3 Connect Y-Left Motor and Limit Cables	p. 35
5.4 Connect Front Plate	p. 36
5.5 Install YR Wire Keeper	p. 38
5.6 Connect Y-Right Motor and Limit Cables	p. 39
5.7 Connect Gantry	p. 40
5.8 Install Y-Right End Cap	p. 42

5.9	Install Grounding Block	p. 44
<b>6.</b>	<b>Spindle / Router</b>	<b>p. 45</b>
6.1	Preparing the Router Drag Chains	p. 45
6.2	Insert Power Cable	p. 46
6.3	Install the Drag Chains	p. 47
6.4	Secure Router & Cable	p. 49
6.5	Install Y-Left End Cap	p. 50
<b>7.</b>	<b>Controller and Bitsetter</b>	<b>p. 51</b>
7.1	Connect the Controller	p. 52
7.2	Install the BitSetter	p. 53
7.3	Tidy Up	p. 54
<b>8.</b>	<b>Where to go next</b>	<b>p. 55</b>
8.1	Machine Configuration	p. 55
8.2	Training	p. 55
8.3	Support and Warranty	p. 55
8.4	Changes	p. 56
8.5	Contact Us	p. 56

# 1. Welcome and Congratulations

The Shapeoko 5 Pro is a high-performance CNC router that comes with everything you need to accurately cut wood, plastic, and aluminum, so you can turn your workbench into a business.

At up to 4 feet in width, Shapeoko 5 Pro is bigger than ever, so you can take on larger jobs or nest more parts together and run the machine longer. It's not just a CNC router, it's a complete system of hardware, software, accessories, and training, built and supported in the USA.

## 1.1 Assembly Notes

- The use of power tools is not recommended for assembly. Use hand tools only.
- Some steps rely on non-tightened fasteners. Do not tighten fasteners beyond finger-tight until instructed.
- Your Shapeoko 5 Pro gantry is powered by stepper motors. When the power is off, moving the motors by hand will cause them to generate electricity. **IMPORTANT:** When moving the gantry by hand, go slowly. The power generated by the stepper motors will feel like bumps. If the red LED on the controller lights up when moving the stepper motors, it's important to slow down because you are pushing electricity back through the board, which could damage the controller.

## 1.2 Technical Support

Have questions? Need help? We have a fully-staffed support team waiting to help if you run into any trouble while assembling your Shapeoko 5 Pro. Just email us at [support@carbide3d.com](mailto:support@carbide3d.com).

### 1.3 Shipping Box 1 Inventory

NOTE: Your Shapeoko 5 Pro kit has been carefully packaged by hand. If you find that you are missing hardware in any step, check the extra hardware bag included in the Open First Box.

If you don't find what you need in the extra hardware bag, or one of your components was damaged in shipping, contact us at [support@carbide3d.com](mailto:support@carbide3d.com) and we will ship you a replacement ASAP.

Below you will find tables to help you verify that you have received all the parts for **Shipping Box 1**.

The **Open First Box** contains all the bits and pieces you'll need to assemble the Shapeoko 5 CNC machine. Take care to keep track of all these items as you'll need some of them during the build itself, and a few of the others after the build is complete and you're ready to use your machine.

Item	Description
Toolkit	Hex Keys 1.5, 2.5, 3,4,5mm Wrench Set: 8, 10, 13mm
Extra Hardware	Additional hardware, spare limit switch
Cable Management	Zip ties (100 pack), adhesive tie down blocks
Workholding Kit	Hulk Clamps x 6, T-Nutz x 12, M6x25mm SHCS x 6
#201	1/4" 3 Flute Square Endmill, Carbide, made in USA
Sweepy 65 v2.0	Clear Polycarbonate Dust Boot
Marker	Carbide3D permanent marker
Baseframe & Hybrid Hardware	Hardware to assemble baseframe and Hybrid Table

The **HDZ Box** contains your Z-Axis assembly, the Gantry stepper motor, and various hardware to complete the assembly. Detailed Description can be found below.

<b>Item</b>	<b>Description</b>
HDZ Assembly	Pre-assembled / Tested HDZ Assembly (Z-Axis)
HDZ Hardware	M6x20mm x 2
End Caps	Y-Left and Y-Right Gantry End Caps
End Cap Hardware bag	M6x30mm x 2, M6x12mm x 2
Stepper Motor	Gantry Stepper Motor (X-Axis)
Stepper Hardware	M5x10mm x 4

The **S5 Electronics Box** contains three (3) sub-boxes: Wiring Harness, Shapeoko Controller, and the Shapeoko 5 Pro Bitsetter. Below is a detailed list of all included components.

<b>Inner Box</b>	<b>Contents</b>	<b>Qty</b>
<b><i>Wiring Harness Box</i></b>		
	Front Plate Extension	1
	Spindle Drag Chain	1
	Wire Keepers	2
	Gantry Shift Drag Chain Extension	2
	M4x6mm Button Head Screws	2
	M3x6mm Socket Head Screws	10
<b>Controller Box</b>		
	USB Cable	1
	Power Cable	1



	Power Pendant Cable	1
<b>Shapeoko 5 Bitsetter</b>		
	Bitsetter Assembly	1
	Bitsetter Cable	1
	M6x25mm Socket Head Cap Screws	2
	Teez-Nutz	2

The **S5 Baseframe Box** contains four (4) baseframe members for the **Shapeoko 5 Pro 4x4** or three (3) baseframe members for **4x2** and **2x2** size machines. Note that each baseframe member has a right and a left side. The right side has wire clips on the covers, and the left side has smooth covers.

There are three (3) additional items that are packed directly into Box 1.

Item	Qty
Y-Left Assembly (Nested in foam inserts)	1
Y-Right Assembly (Nested in foam inserts)	1
Cable Track (Placed below the Basefram Assembly)	1

#### 1.4 Shipping Box 2 Inventory

Item	Description	Qty
X-Axis Gantry Assembly	Assembled and Tested S5 Gantry	1
Hybrid Tasble Extrusions	Extruded aluminum pieces with pre-drilled holes	12
MDF Strips	MDF to be used as a wasteboard	12

NOTE: Shapeoko 5 Pro 2x2 only requires six (6) Hybrid Table Extrusions and six (6) MDF Strips.

## 2. Baseframe and Gantry

Items Required	Qty
Y-Right Assembly	1
Y-Axis Assembly Hardware: M6×16mm Button Head Cap Screws	16
Cable Track	1
Baseframe Members (4x4 Size)	4
Baseframe Members (4x2 and 2x2 Size)	3
Y-Left Assembly	1
Tool Bag	1
X-Axis Gantry Assembly	1

NOTE: Only the Shapeoko 5 Pro 4x4 size requires four (4) baseframe members. The Shapeoko 5 Pro 4x2 and Shapeoko 5 Pro 2x2 sizes use three (3) baseframe members.

### 2.1 Unpack Shipping Box 1

1. In Shipping Box 1, locate the box labeled **Open First**
2. Remove the bag containing the tool kit.
3. Remove the bag labeled **Baseframe Hardware**
4. Locate the **S5 Electronics Box** and the **HDZ Box** and set them aside.
5. Locate and remove the **Baseframe Box** from between the two Y-Rails.

## 2.2 Position Baseframe

1. Open the **Baseframe Box** and remove the four (4) baseframe members.
2. Position the four (4) baseframe members horizontally across your table approximately 15.7 inches (400 mm) apart, center to center. See Figure 1-1.
3. Ensure that the wire clips face to the right.
4. Open the wire clip on the end of each baseframe member. This will make routing the front plate extension easier when the time comes.

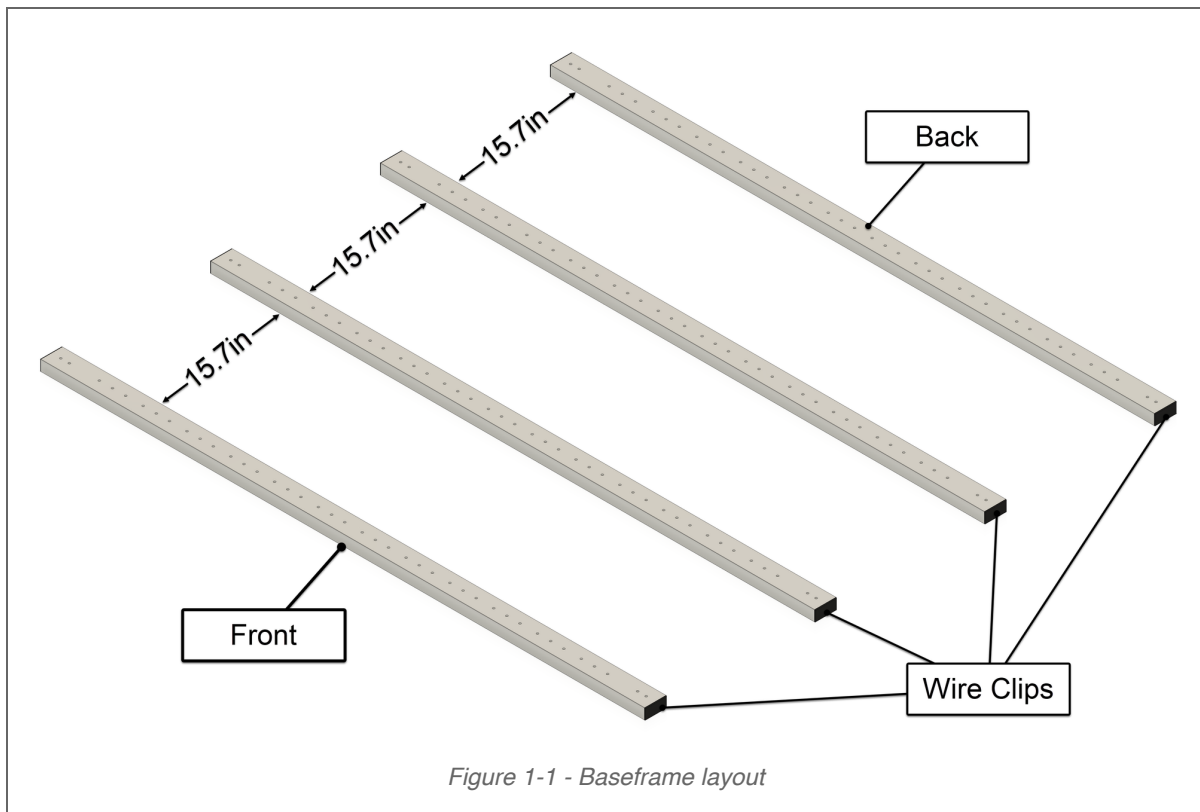

## 2.3 Install Y-Right Assembly

NOTE: This step is much easier with two people. The Y-assembly is heavy and unevenly weighted, and can easily tip over if set upright before attaching it to the baseframe.

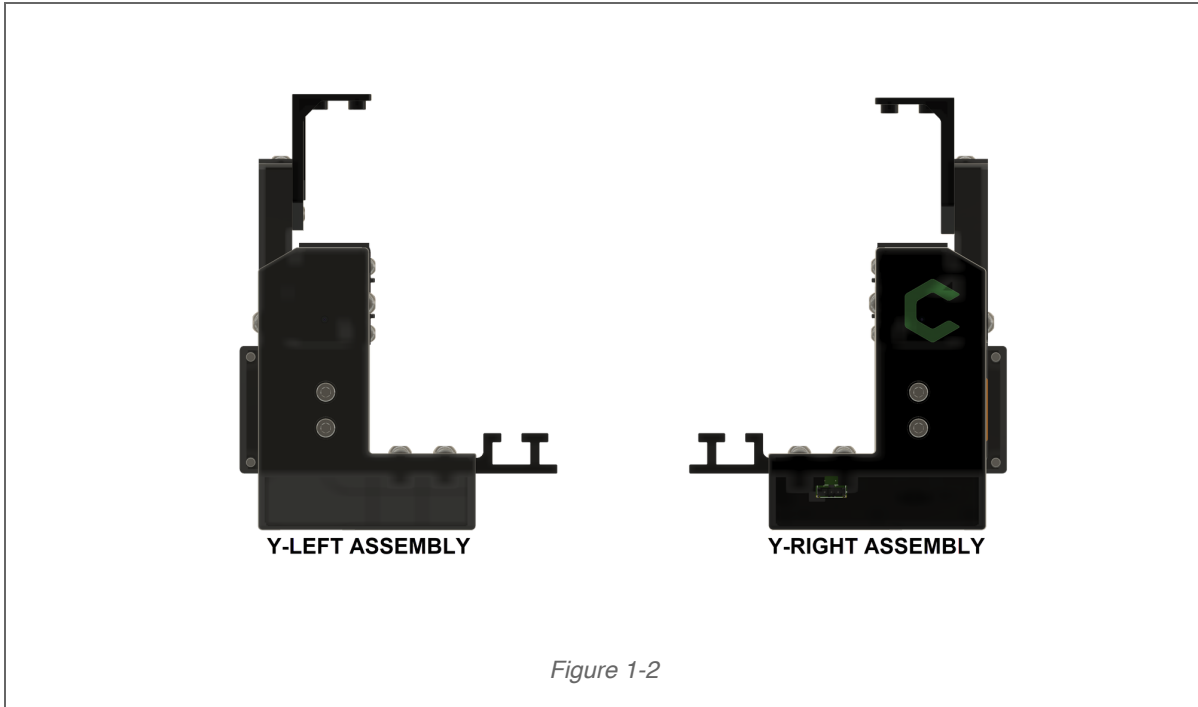

1. Remove the **Y-Right Assembly** from its protective foam in Shipping Box 1. The Y-Right has a Carbide 3D logo on the front plate see Fig 1-2 for reference.
2. Set the **Y-Right Assembly** on the right side of the baseframe. See Fig. 1-2.1.
3. Align the front edge of the Y-Right Assembly with the front edge of the first baseframe member.
4. Align with the outside set of screw holes in each baseframe member.
5. Remove eight (8) M6x16mm BHCS from the **Basefram Hardware** bag.
6. Use a 4mm hex key and eight (8) M6x16mm BHCS to attach the Y-assembly. See Fig. 1-2.1. Snug the screws but don't fully tighten.
  - Y-Right assembly is attached in four (4) locations.
  - At location 1, insert the BHCS through the holes in the end cap.

NOTE: Don't worry about squaring the baseframe yet, we'll do that after installing the gantry.

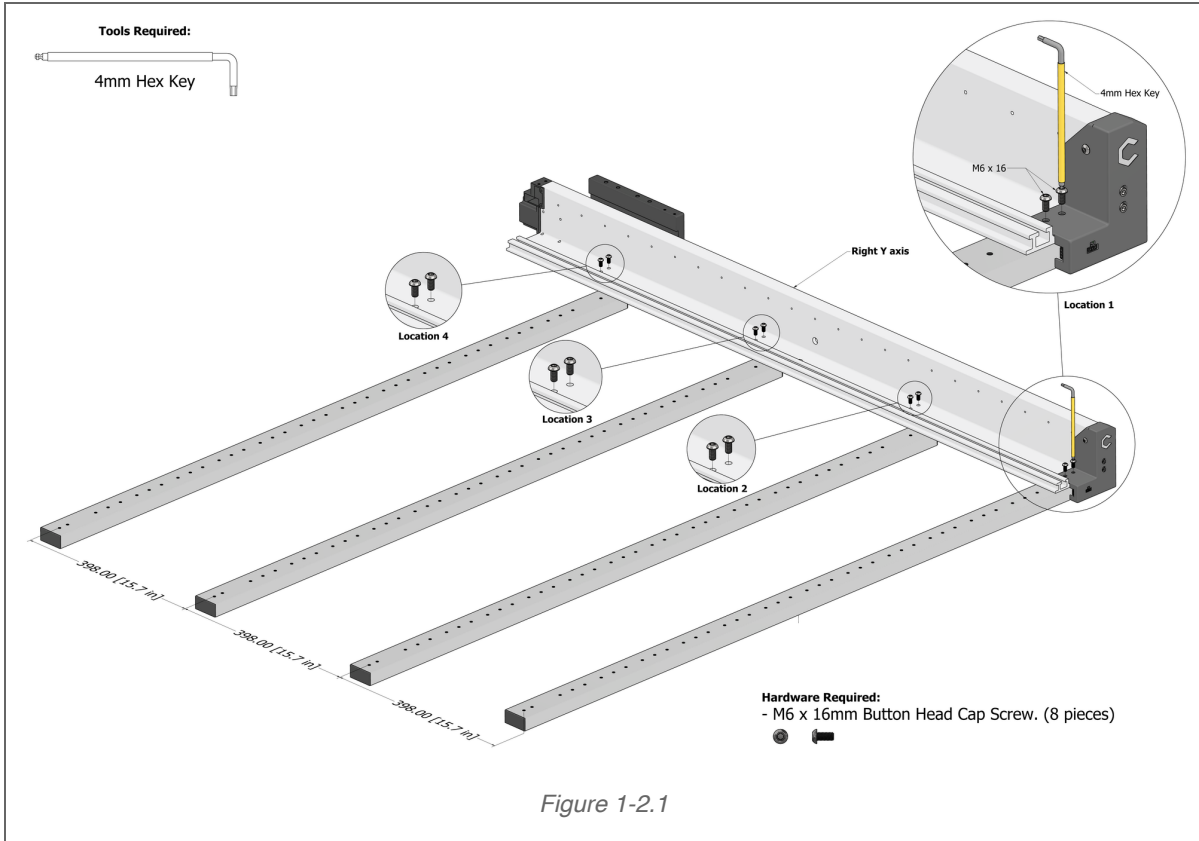

## 2.4 Install Y-Left Assembly

NOTE: This step is much easier with two people. The Y-assembly is heavy and can easily tip over if set upright before attaching it to the baseframe.

1. Remove the **Y-Left Assembly** from its protective foam in Shipping Box 1. Y-Left has a blank front plate, see Fig 1-2 for reference.
2. Set the **Y-Left Assembly** on the left side of the baseframe. See Fig. 1-3.
3. Align the front edge of the Y-Left Assembly with the front edge of the first baseframe member.
4. Align with the last set of screw holes in each baseframe member.
5. Use a 4mm hex key and eight (8) M6×16mm BHCS to attach the assembly. See Fig. 1-3. Snug the screws but don't fully tighten.
  - Y-Left assembly is attached in four (4) locations.
  - At location 1, insert the BHCS through the holes in the end cap.

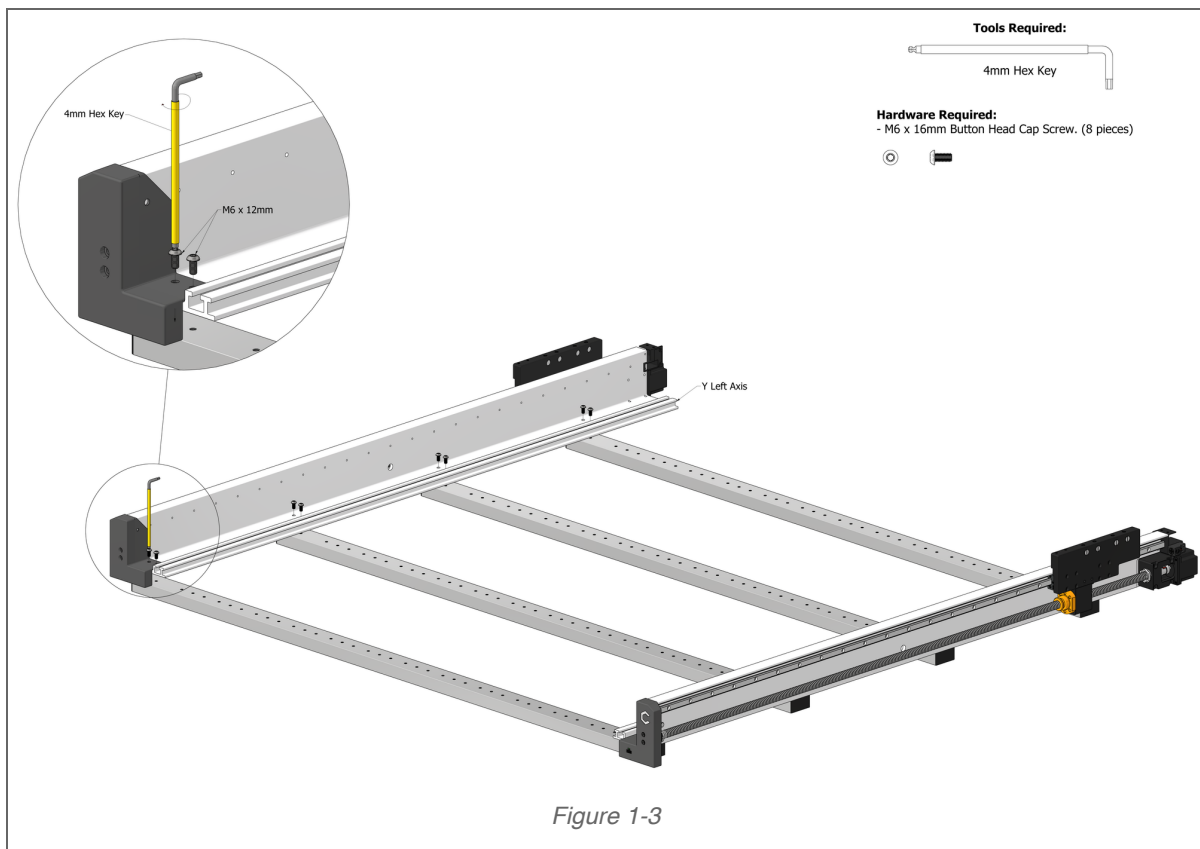

**TIP:** Each of the baseframe holes on the Y-Left extrusion is slotted. When attaching the gantry, remember you can slide the entire Y-Left Assembly inward/outward 2mm to align the gantry with the cross dowels.

## 2.5 Install the Cable Track

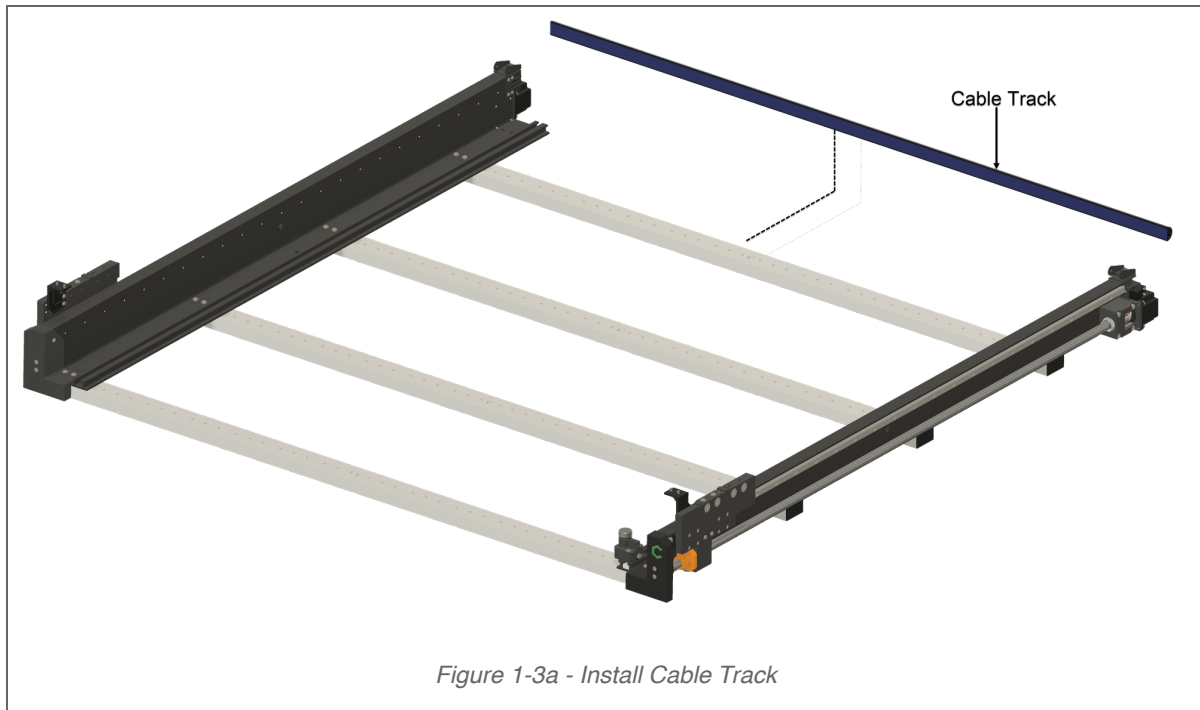

1. Remove the adhesive cable track from **Shipping Box 1**.
2. Install the **Cable Track** on the last baseframe member at the back of the machine.
3. Remove the clear protective coating.
4. Remove the blue adhesive cover.
5. Position with the opening facing up.
6. Align the cable track to the bottom edge of the baseframe.
7. Center the cable track between the two Y-Axis assemblies, there will be about 4 inches (100 mm) on either side.
8. From one side, press firmly as you run your hand over the entire length of the track.



## 2.6 Prepare for Gantry Install

1. Pull the **Y-Right Carriage** to the front of the machine. See Fig. 1-4.
2. Pull the **Y-Left Carriage** to the front of the machine.
3. Use a 5mm hex key to remove the two (2) M6×20mm SHCS from the rear position of the Y-Right and Y-Left carriages.

NOTE: Keep the M6×20mm SHCS close by. You will need them to install the gantry.

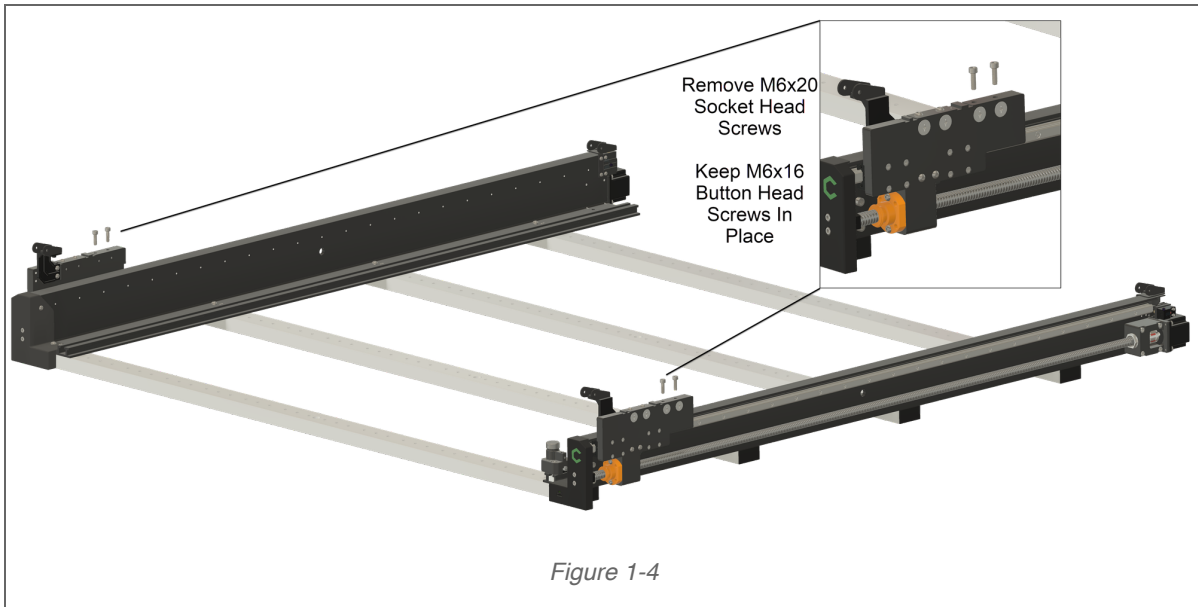

## 2.7 Open Shipping Box 2

1. Open Shipping Box 2. This box contains:
  - Gantry Assembly (note that the X-Axis drag chain is pre-installed on the gantry).
  - Hybrid Table (Aluminum extrusions and MDF Strips).
  - Hybrid Table hardware.

## 2.8 Install Gantry Assembly

NOTE: This step is much easier with two people. The X-Axis gantry assembly is heavy and can easily tip over. If the gantry tips over, the mating face on the bottom edge could be irreparably damaged, which will prevent the gantry from attaching properly to the Y-Axis assemblies.

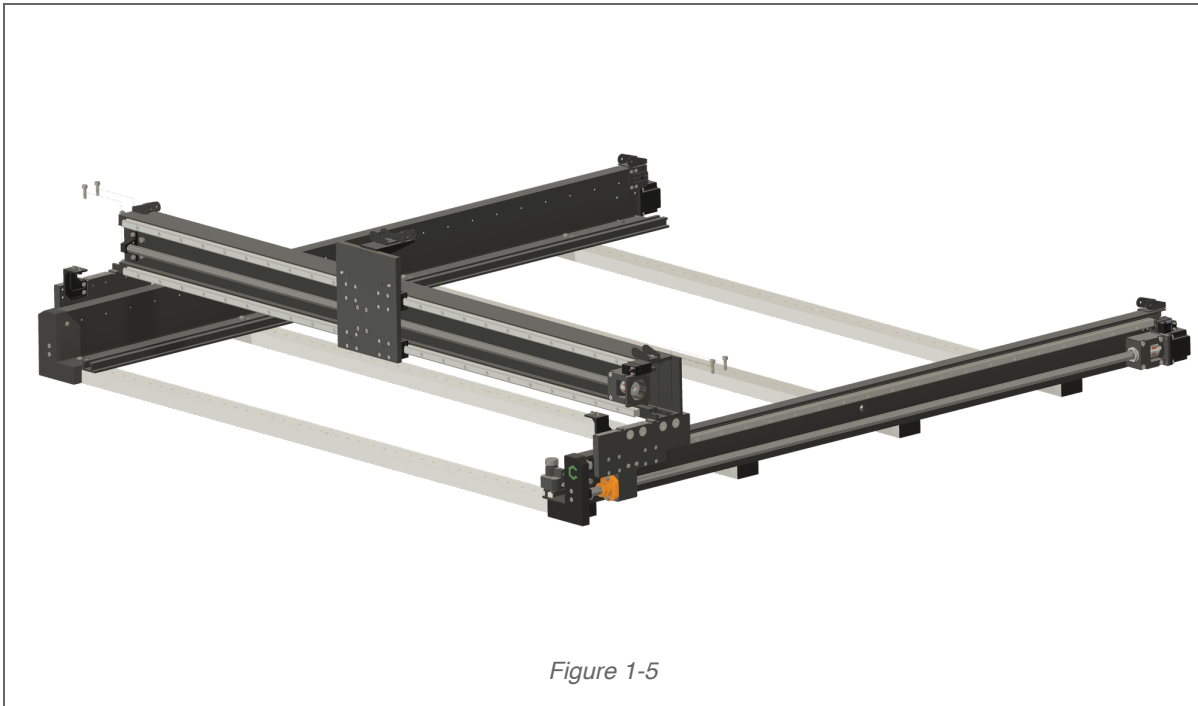

1. Lift the **Gantry Assembly** from the box and set it onto the rear position of the Y-Axis carriage plates, over the now-empty screw holes. See Fig. 1-5.
2. Ensure that the large X-Axis carrier plate faces the front of the machine.
3. Hold the gantry firmly in place as you complete the steps on the following page.
4. From the right side of the machine, push the gantry toward the front of the machine until it engages with the reference edge on the top of the Y-Right carriage plate. See Fig. 1-6.

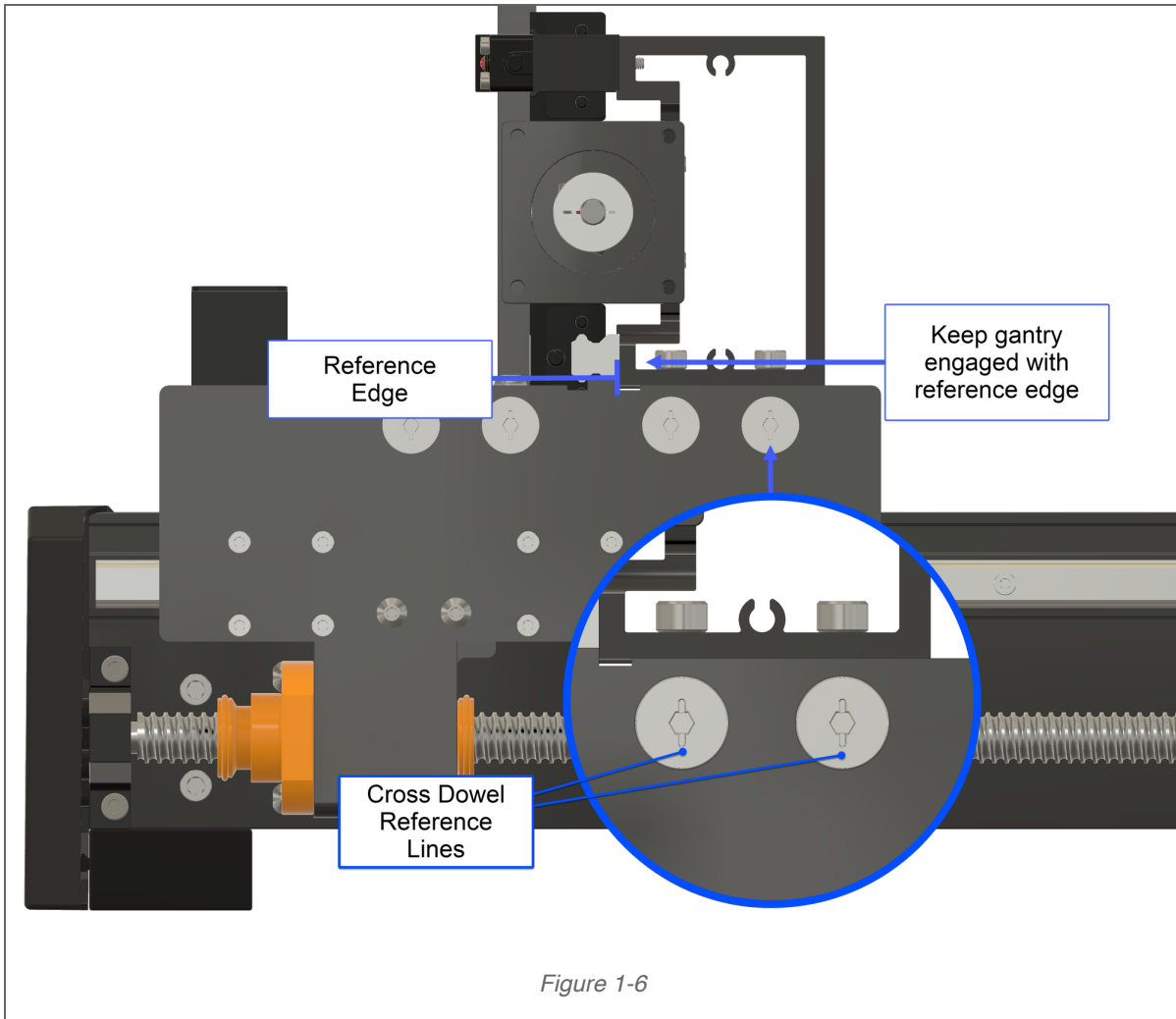
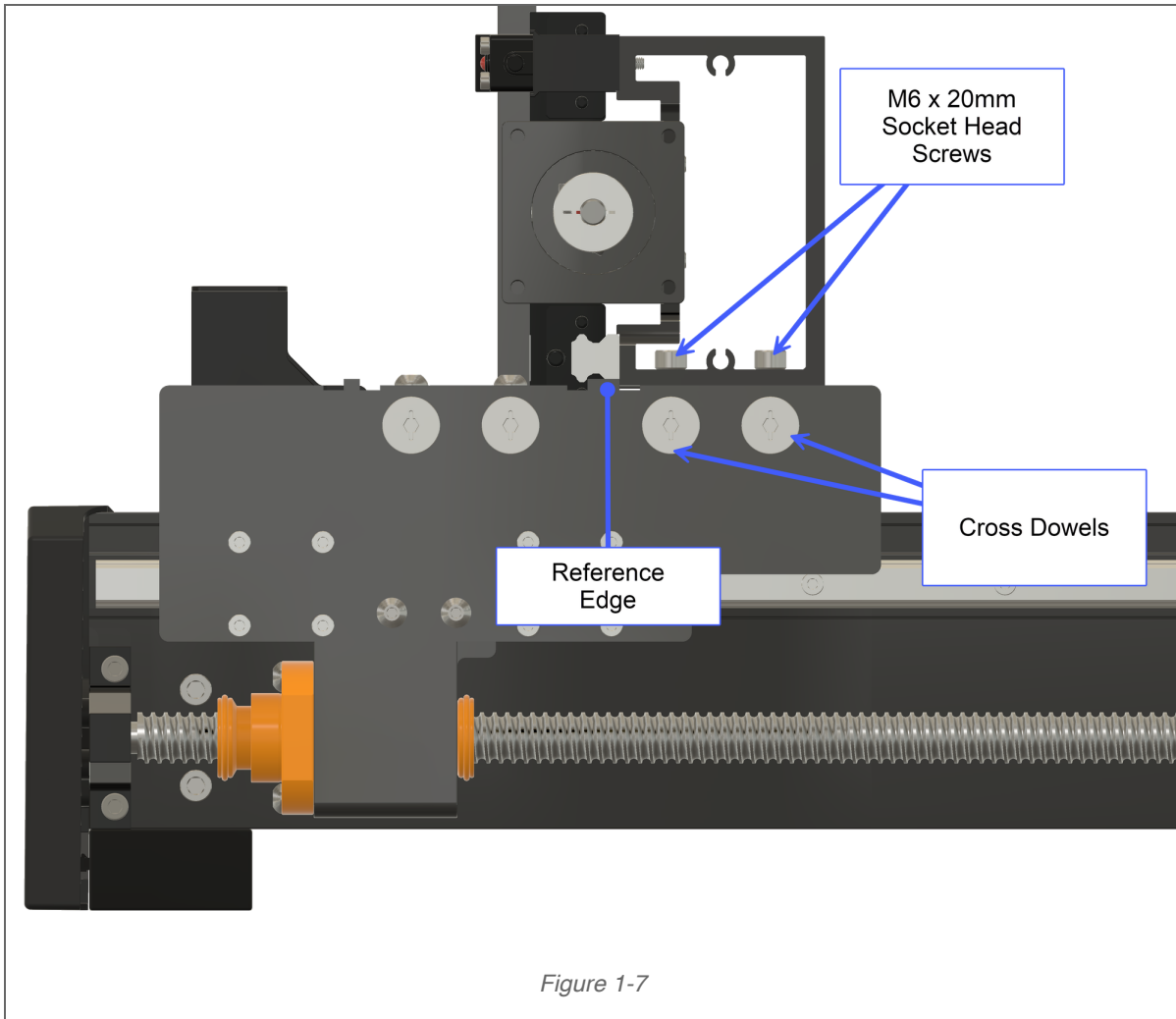

Figure 1-6

5. Orient the **Cross Dowels** so that the reference line on the face of each is vertical. See Fig. 1-7.
6. Use a 5mm hex key to loosely re-insert the two (2) M6×20mm SHCS to attach the gantry to the Y-Right Assembly. See Fig. 1-7.
7. From the left side of the machine, push the gantry forward until it engages with the reference edge on the top of the Y-Right carriage plate.



8. Orient the **Cross Dowels** so that the reference line on the face of each is vertical. See Fig. 1-7.
9. Use a 5mm hex key to loosely re-insert the two (2) M6×20mm SHCS to attach the gantry.
10. Ensure that both Y-carriage plates are still in the furthest forward position.
11. Keep pressure on the gantry to keep it engaged with the reference edge on each carriage as you fully tighten all four (4) M6×20mm SHCS.

## 2.9 Square the Machine

1. Check that the **Y-Right Carriage** and the **Y-Left Carriage** are still pushed to the front of the machine.
2. Starting on the right side, use a 4mm hex key to fully tighten the first pair of M6×16mm BHCS to secure the Y-Right assembly to the first baseframe member.
3. Moving to the left side, use a 4mm hex key to fully tighten the first pair of M6×16mm BHCS.
4. Push the gantry back to the second baseframe member and fully tighten the pair of screws on the right side, then on the left side.
5. Push the gantry back to the third baseframe member and tighten the screws on the right, then on the left.
6. Push the gantry all of the way to the back of the machine until it hits the Y-motor mounts and tighten the screws on the right, then on the left.

### 3. HDZ (Z-Axis)

Items Required	Qty
HDZ (Z-Axis)	1
HDZ Hardware: M6x20mm Socket Head Cap Screws	4
X-Motor Hardware: M5x10mm Socket Head Cap Screws	4
X-Axis Stepper Motor	1

#### 3.1 Install the HDZ

1. Open the **HDZ Box** and remove the assembled HDZ (Z-Axis Assembly), HDZ hardware, X-Axis stepper motor, X-Axis stepper motor hardware.
2. Set the Y-Left and Y-Right end caps and hardware aside. You will not need them until step 4 and step 5.
3. Align the HDZ with the two (2) short locating pins on the front of the X-Axis carrier plate and push it onto the carrier plate. See Fig. 2-1.
  - Z-Axis stepper motor on top.
  - The HDZ slides onto the two (2) locating pins. Note that it may not slide completely onto the pins until the four SHCS are fully tightened.
4. Hold the HDZ in place as you loosely insert four (4) M6x20mm SHCS. See Fig. 2-1. **Do not let go of the HDZ until at least two (2) of the SHCS are installed.**
5. Use a 5mm hex key to fully tighten the SHCS and secure the HDZ to the carrier plate.

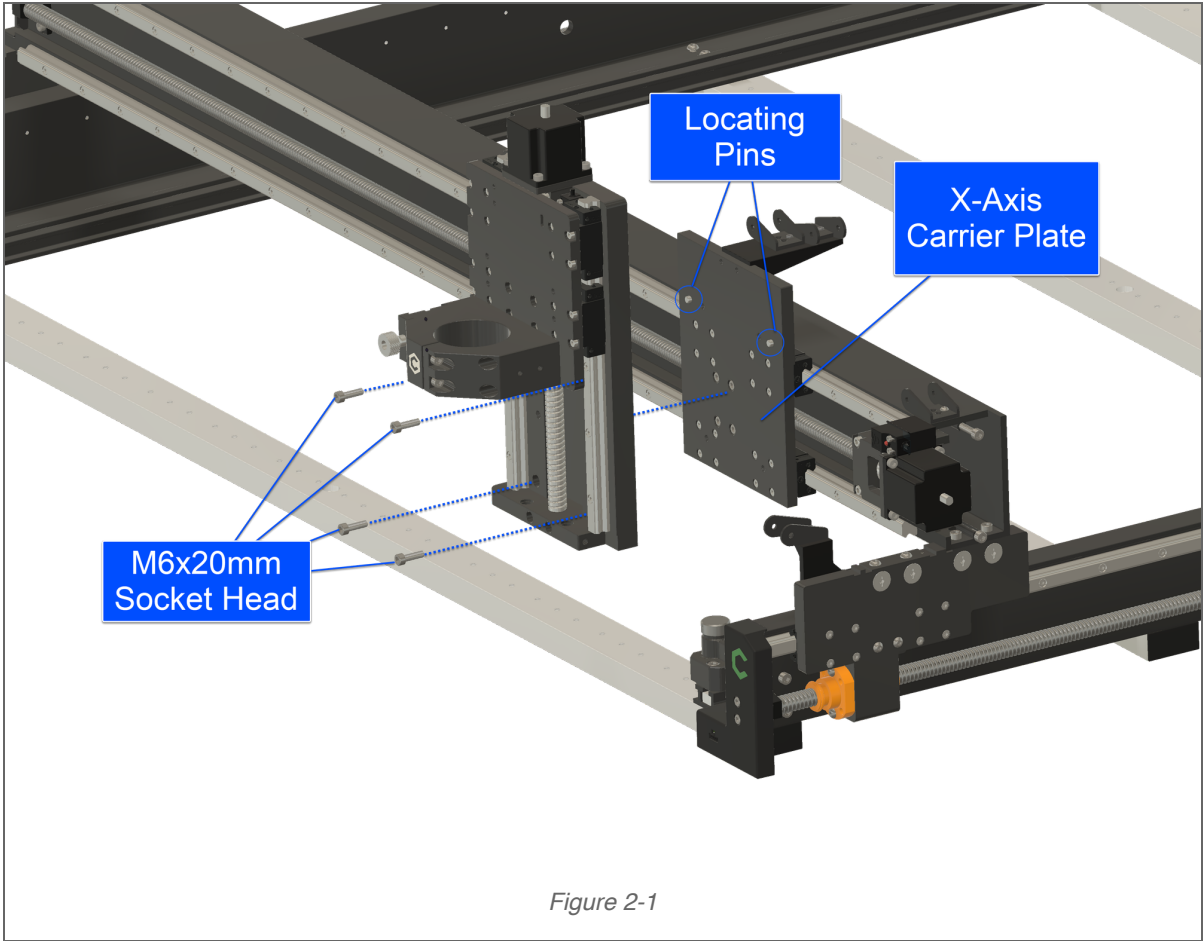
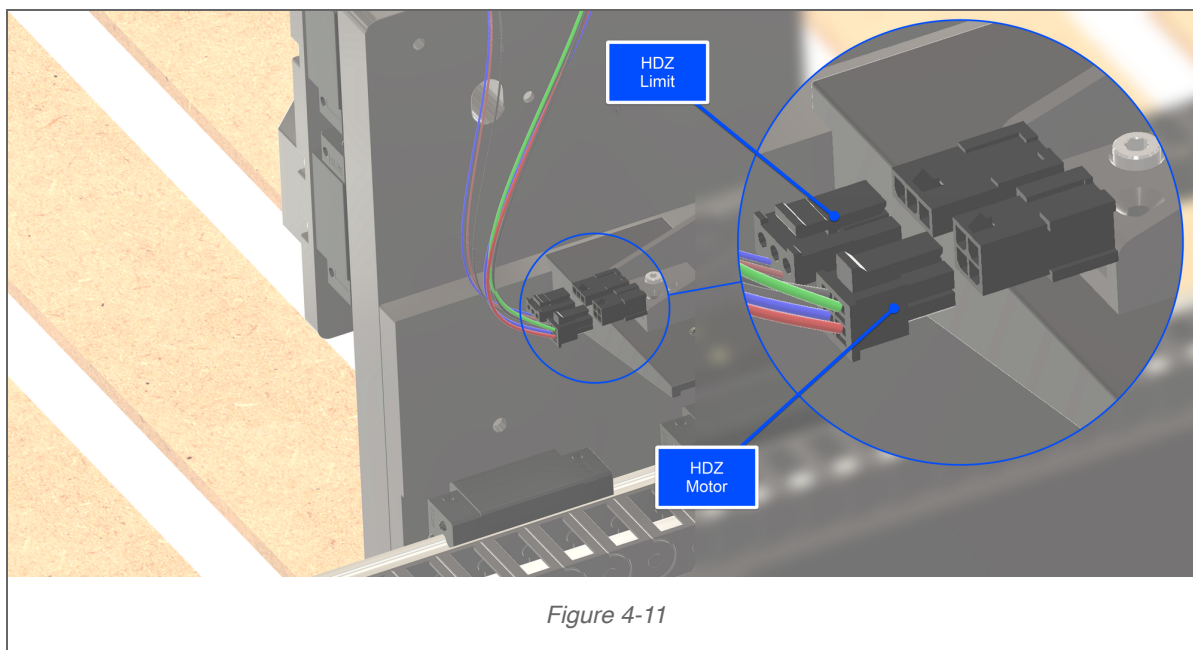

Figure 2-1

### 3.2 Connect Z-Axis Cables



1. At the back of the HDZ, connect the Z-Axis motor and Z-Axis limit switch cables to the pre-wired extensions on the Gantry. See Fig. 4-11.

### 3.3 Install X-Axis Stepper Motor

1. Locate the X-motor in the HDZ box.
2. Orient the X-motor with the motor coupler facing toward the mount. See Fig. 2-2.
3. Ensure that the motor wires face the rear of the machine. See Fig. 2-3.
4. Rotate the motor shaft until the motor coupler is lined up with the ball-screw coupler inside the mount.



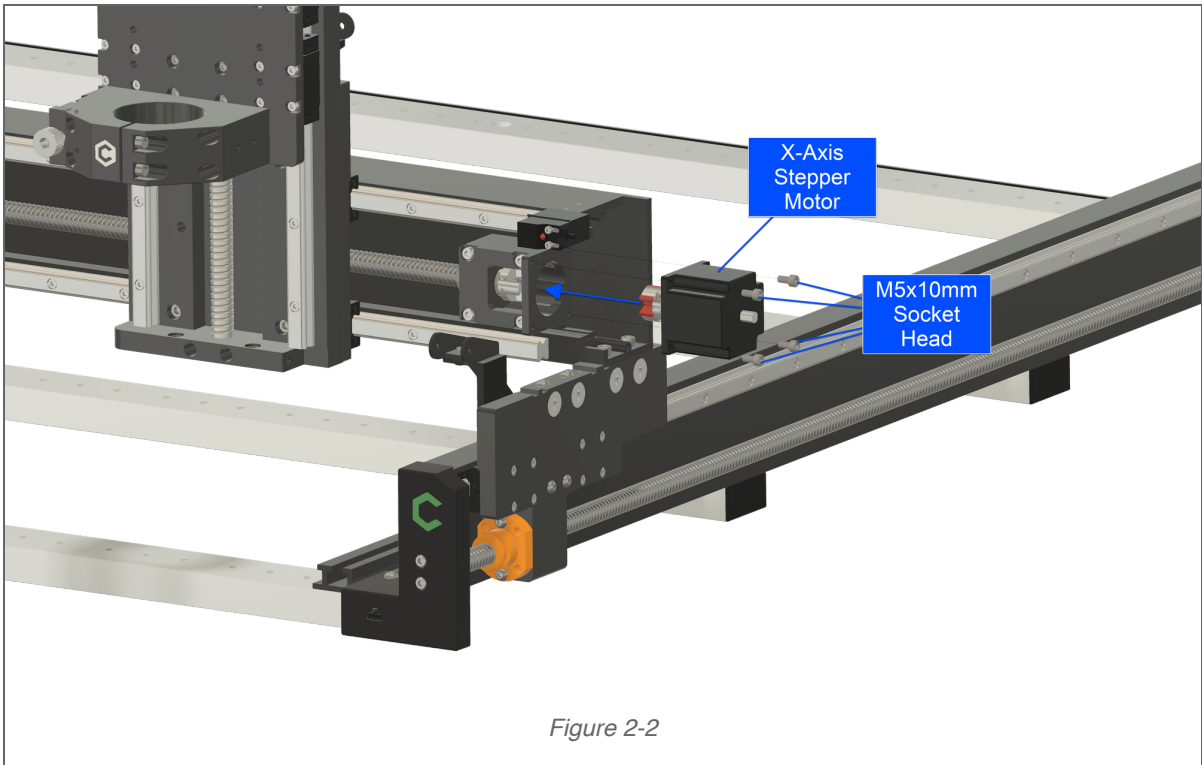
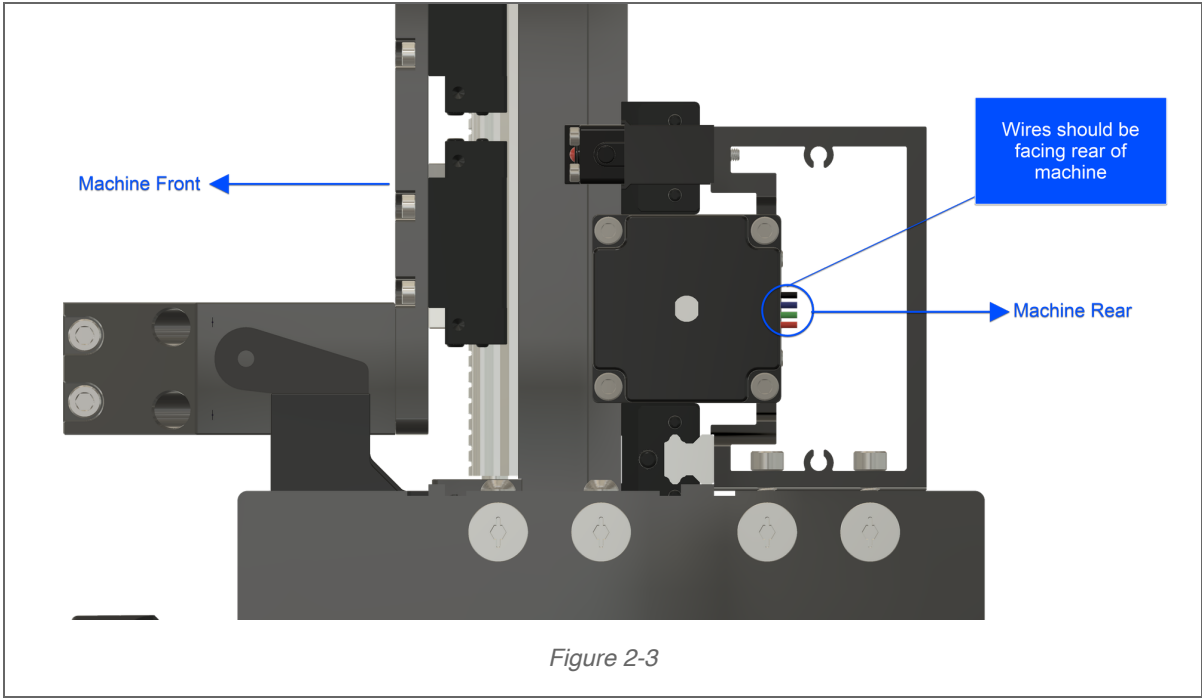

5. Press the couplers together until fully seated and the motor is flush with the motor mount. See Fig. 2-4.
6. Use a 4mm hex key and four (4) M5x10mm SHCS to secure the X-motor to the motor mount. Fully tighten.

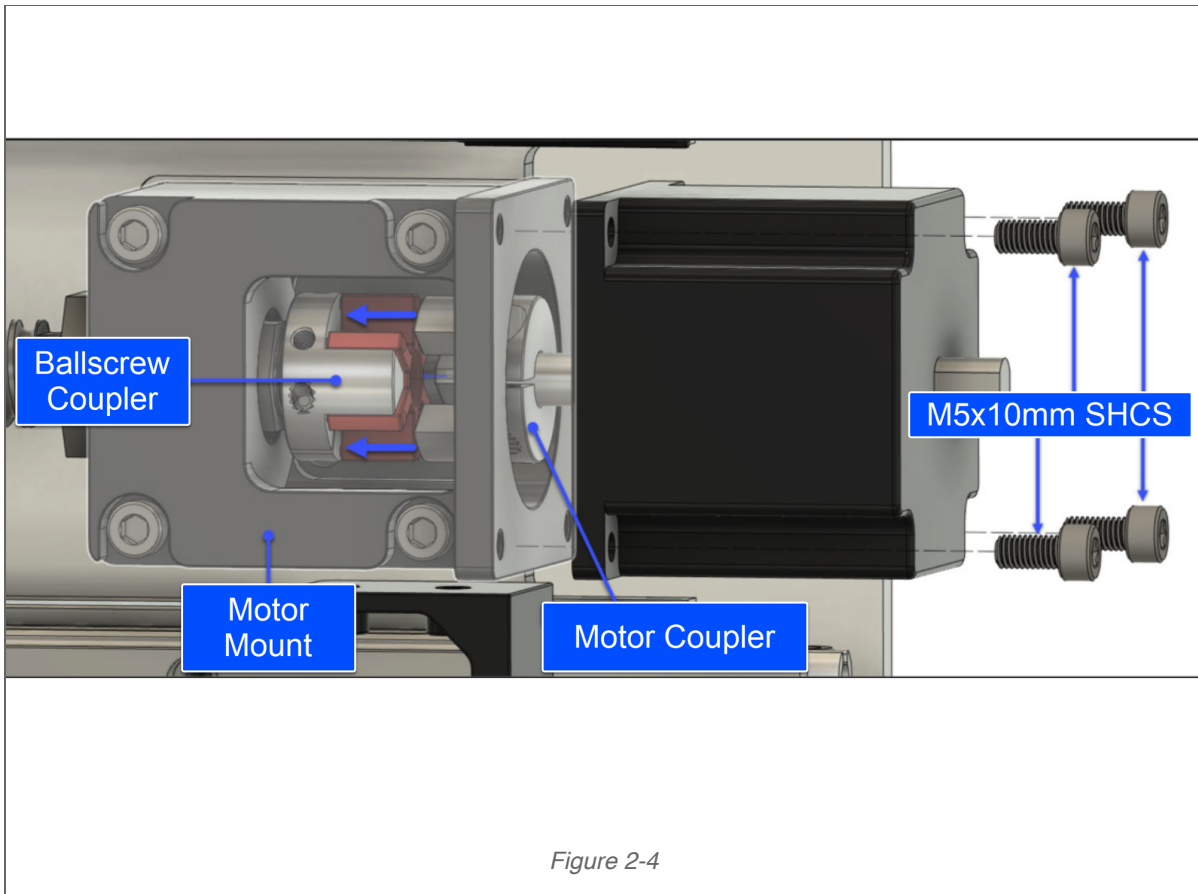

**WARNING:** Do not adjust the coupler. Each ballscrew and motor assembly is pre-assembled according to very specific standards, manually adjusting the coupler could negatively affect the performance of your machine.

## 4. Hybrid Table

NOTE: Do not use power tools to build the Hybrid Table. It is very easy to apply too much torque and strip threads or cross-thread a screw.

Items Required	Qty (4x4)	Qty (4x2)	Qty (2x2)
Hybrid Table Extrusions	12	12	6
M6x10 Flat Head Screws	96	72	36
MDF Strip	12	12	6
M6x20 Socket Head Cap Screws	48	36	18

## 4.1 Install Extrusions

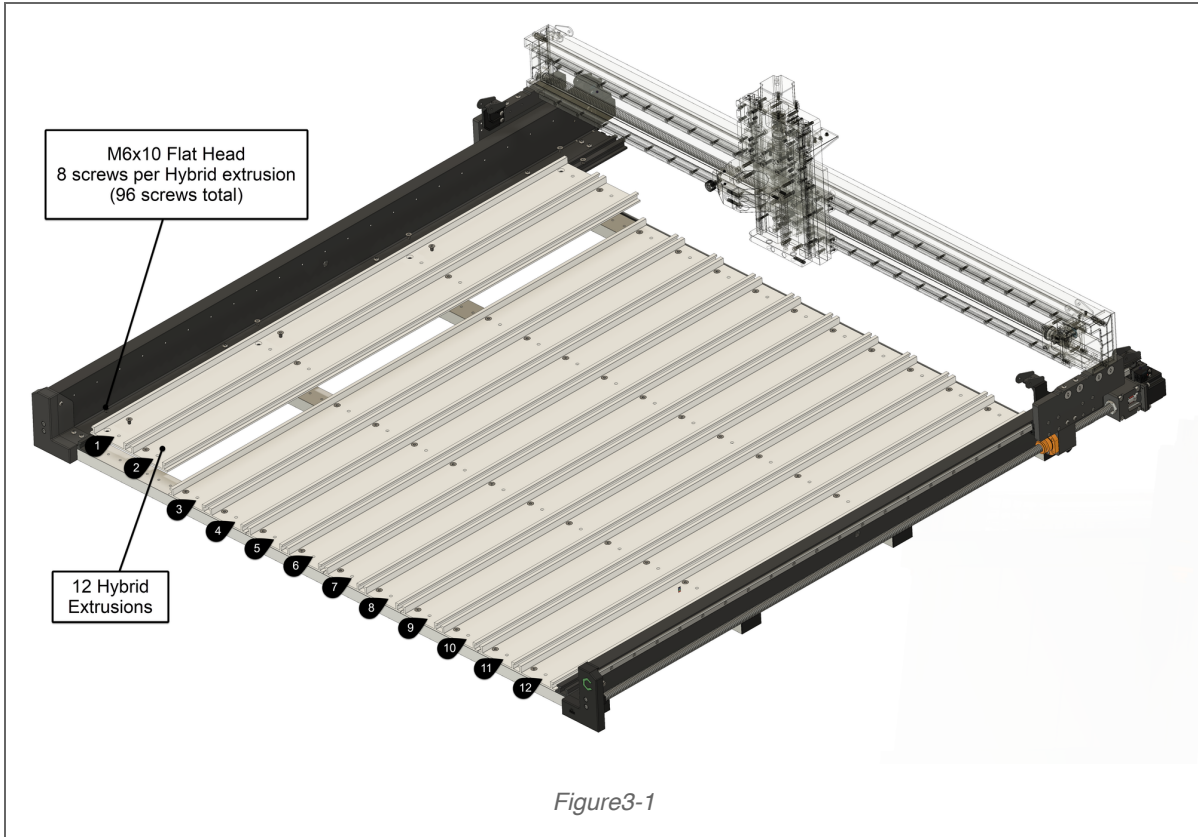

1. Locate the **Hybrid Table Extrusions** and **MDF Strips** from **Shipping Box 2** (the MDF Strips are nested inside the extrusions)
2. Lay the twelve (12) aluminum Hybrid Table Extrusions across the baseframe, right to left. (Only six (6) extrusions are required for the 2x2 machine.)
3. Use a 4mm hex key and eight (8) M6x10mm FHS to **loosely** attach each extrusion. Insert the screws from front to back. See Fig. 3-1.
4. Fully tighten all screws to secure the **Hybrid Table Extrusions**.

## 4.2 Install MDF Strips

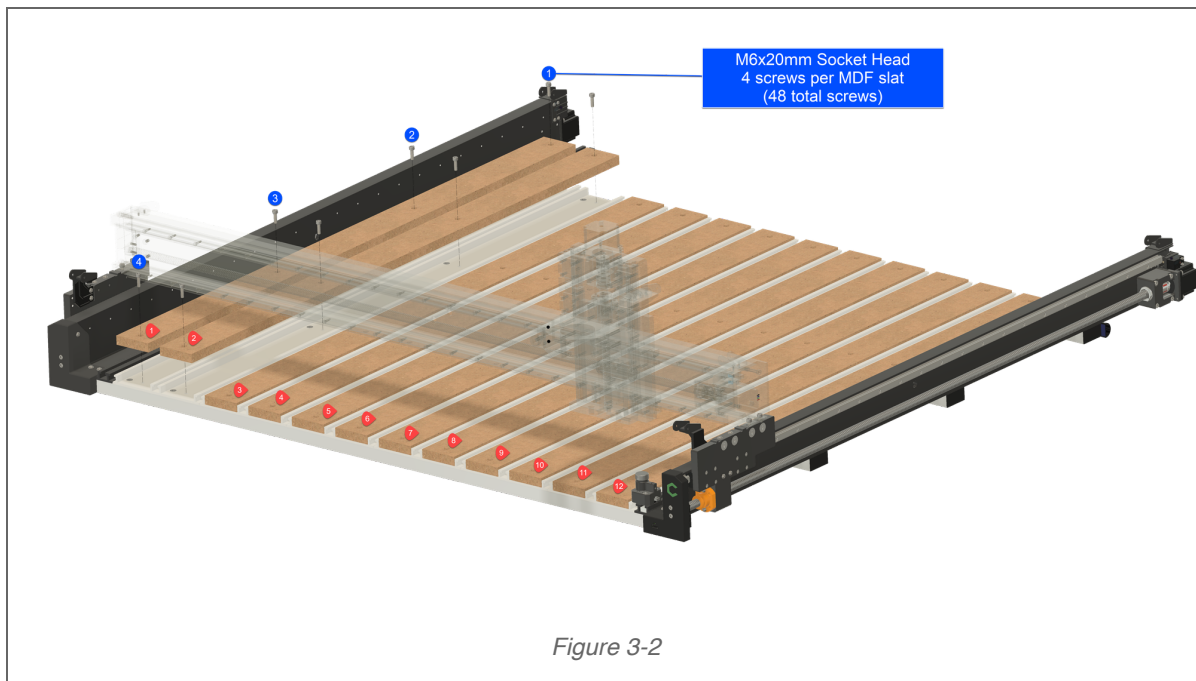

1. Position the twelve (12) **MDF Strips** inside the Hybrid Table Extrusions. See Fig. 3-2.
2. Use a 5mm hex key and four (4) M6×20mm SHCS to **loosely** attach each MDF Strip. Insert the screws from front to back.
3. Fully tighten all screws to secure the **MDF Strips**.

## 5. Wiring Harness

The Shapeoko 5 Pro wiring has been fully tested before shipping and is expected to be plug-and-play during the assembly process.

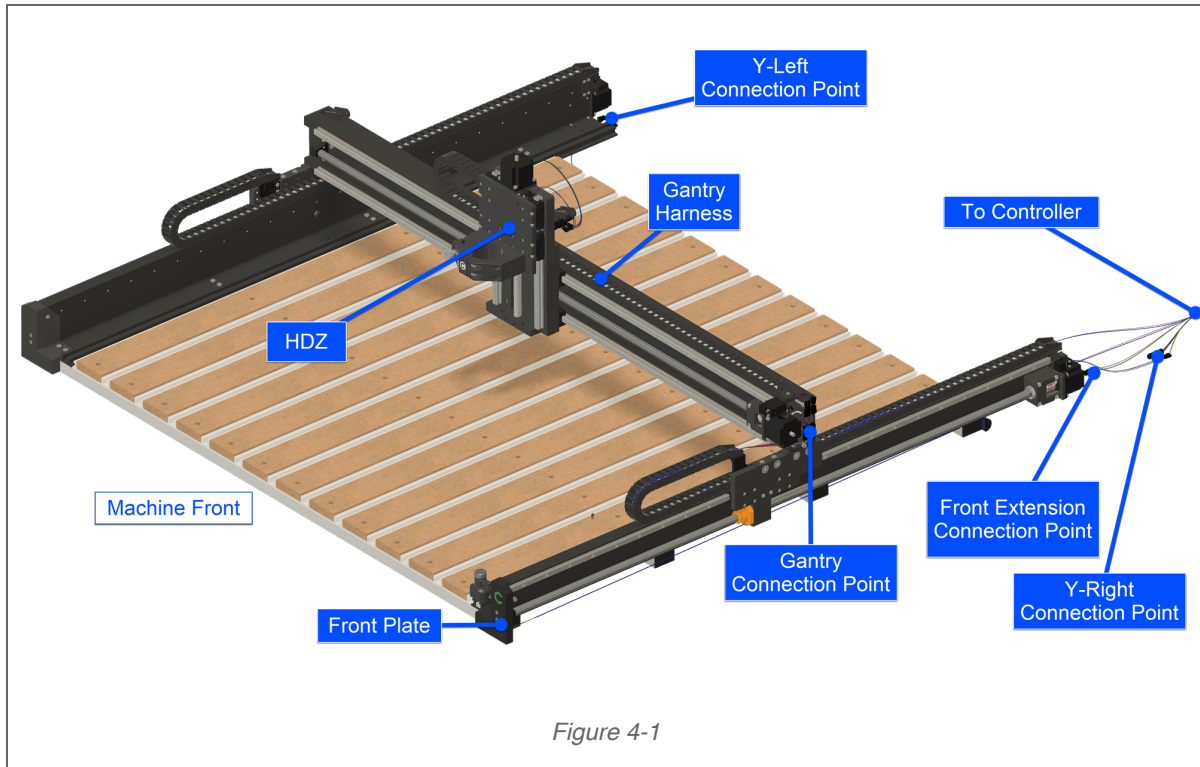

Looking closer at the wiring harness you will find two (2) separate harnesses bundled together:

1. The larger harness controls the motors and LED.
2. The smaller harness controls the limit switches and grounding.

The harness has several branches, each branch controls a different segment of your machine. All branches are shown in **Fig. 4-2** and a detailed description of each branch's connection points can be found in the table below:

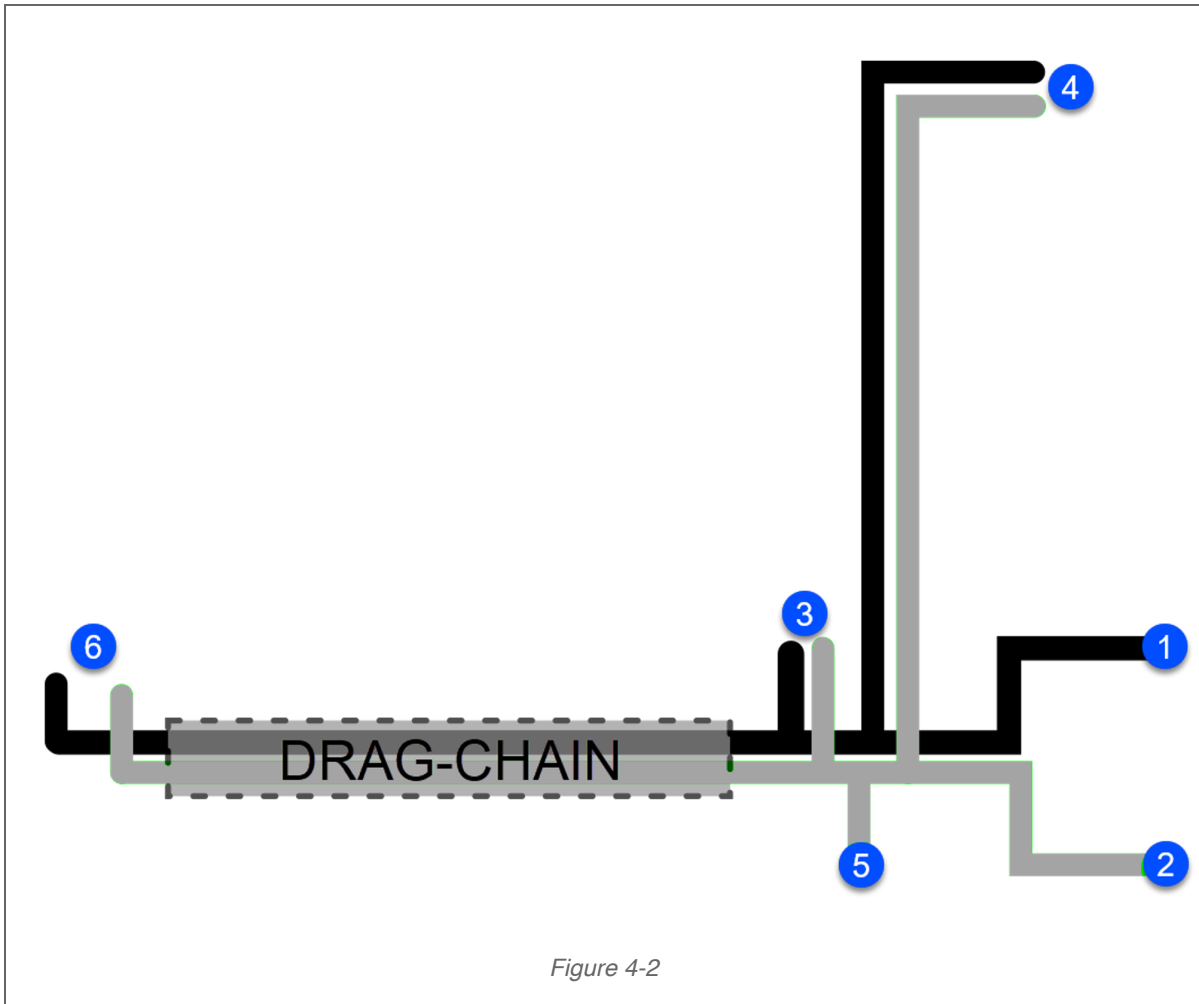

Item	Name	Connectors	Connects To:
1	Motor Harness	1	Connects to Controller
2	Limit Harness	1	Connects to Controller
3	Y-Right Connection Point	2	Y-Right Motor, Y-Right Limit
4	Y-Left Connection Point	2	Y-Left Motor, Y-Left Limit
5	Front Plate Connection Point	1	Front Plate Extension
6	Gantry Connection Point	6	X Motor, Z Motor, LED, X Limit, Z-Limit, GND

## 5.1 Install Wiring Harness

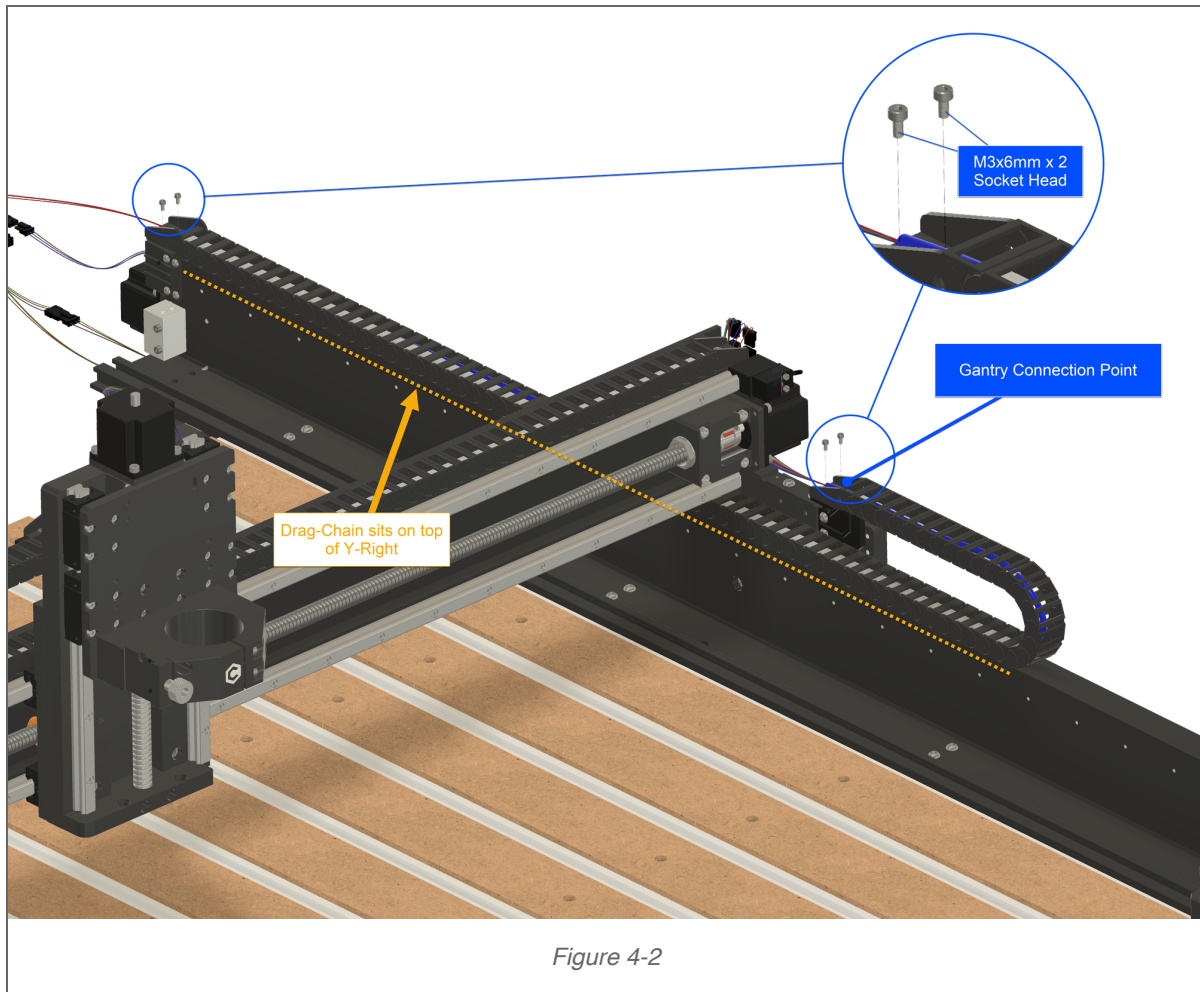



1. Remove the wiring harness and drag chain hardware bag from the **Wiring Harness Box** (found inside the main S5 Electronics Box).
2. Unroll and lay the wiring harness on the baseframe running parallel with the **Y-Right** assembly.
3. Lift the drag chain, slide it under the gantry, and place it on top of the Y-Right assembly.
4. Curl the **Gantry Connection Point** of the wiring harness up so that it rests on the carrier plate bracket. See Fig. 4-2.
5. Use a 2.5mm hex key and two (2) M3x6mm SHCS to secure the drag chain at both ends. Fully tighten. See Fig. 4-2.
6. Put the drag chain hardware bag, with the remaining screws, back in the Wiring Harness Box. You'll need them when we install the router drag chains in Step 5.

## 5.2 Install YL Wire Keeper

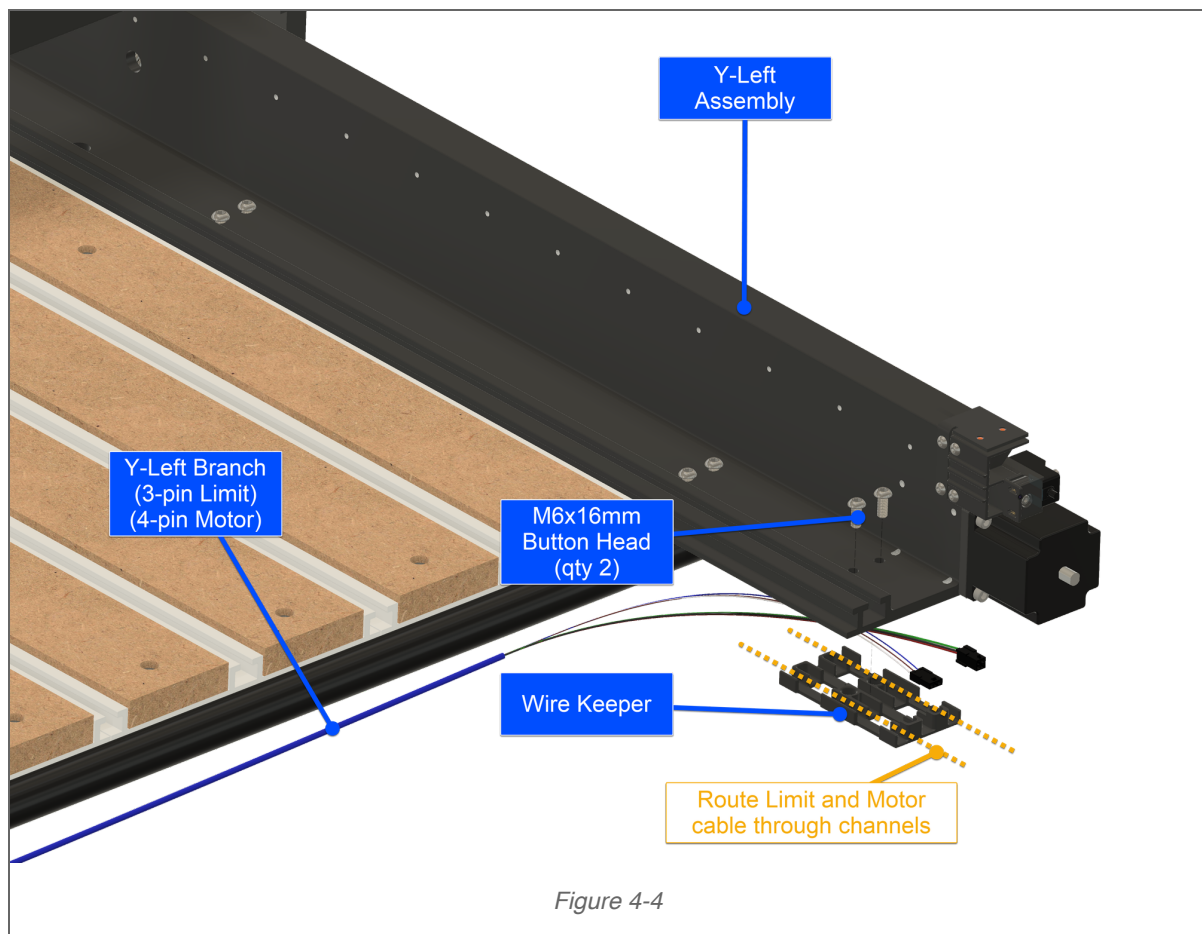

NOTE: The wire keepers provide a route to keep your cables protected and maintain their position below the Y-Axis assemblies

1. Move to the back of the machine.
2. Locate the long Y-Left wiring bundle extending from the wiring harness (the long bundle *NOT* inside the drag chain).
3. Using a Wire Keeper from the **Wiring Harness Box**
4. Place the wire keeper under the Y-Left assembly. See Fig. 4-4.
5. Route the Motor and Limit cables inside the channels on the wire keeper.
6. Align the screw holes in the wire keeper with those in the assembly.
7. Use a 4mm hex key and two (2) M6×16mm BHCS to attach the wire keeper to the Y-Left assembly. Fully tighten. See Fig. 4-4.

NOTE: When securing the wire keepers, make sure all cables are seated in channels and will not be pinched/crushed when keepers are tightened

### 5.3 Connect Y-Left Motor and Limit Cables

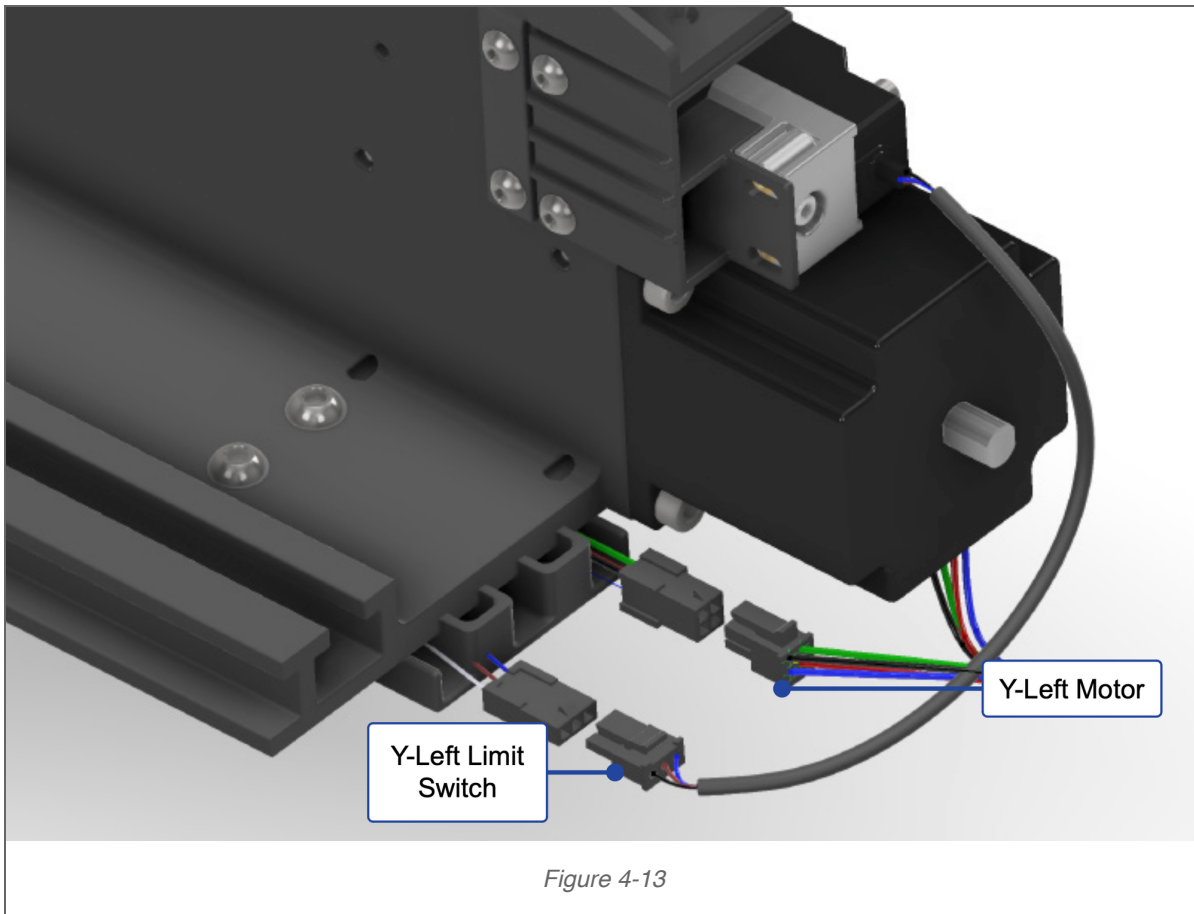

1. Locate the two (2) connectors, 4-pin Y-Left-motor and 3-pin Y-Left-limit switch, exiting from the Y-Left wire keeper.
2. Connect the Y-Left stepper motor. See Fig. 4-13.
3. Connect the Y-Left limit switch. See Fig. 4-13.

## 5.4 Connect Front Plate

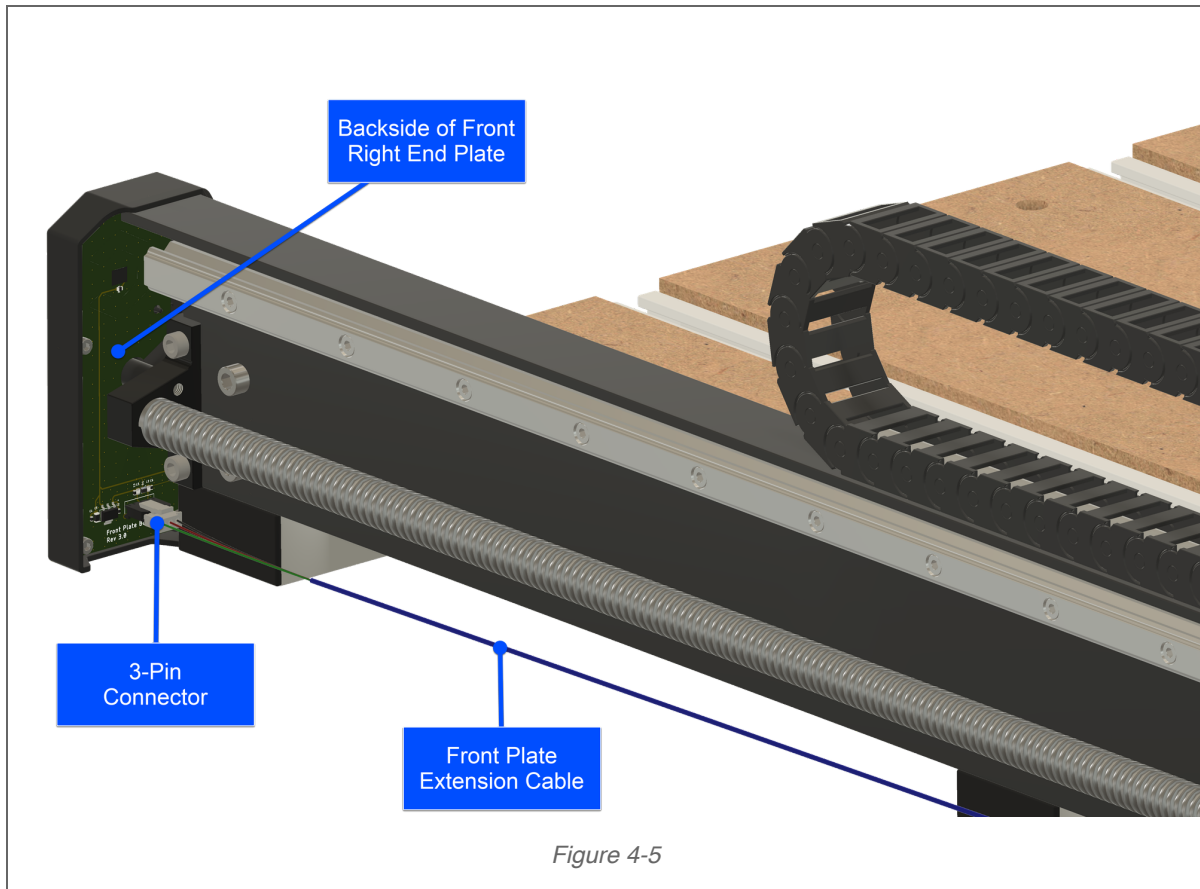

1. Locate the front plate extension cable (3-pin to 4-pin) in the Wiring Harness box.
2. Plug the cable's 3-pin connector into the 3-pin outlet on the back side of the front plate. See Fig. 4-5.
3. Moving towards the back of the machine, snap each wire clip over the cable.
4. Direct the end of the cable past the final baseframe member and under the end of the Y-Right assembly.

## Connect Front Plate to Harness

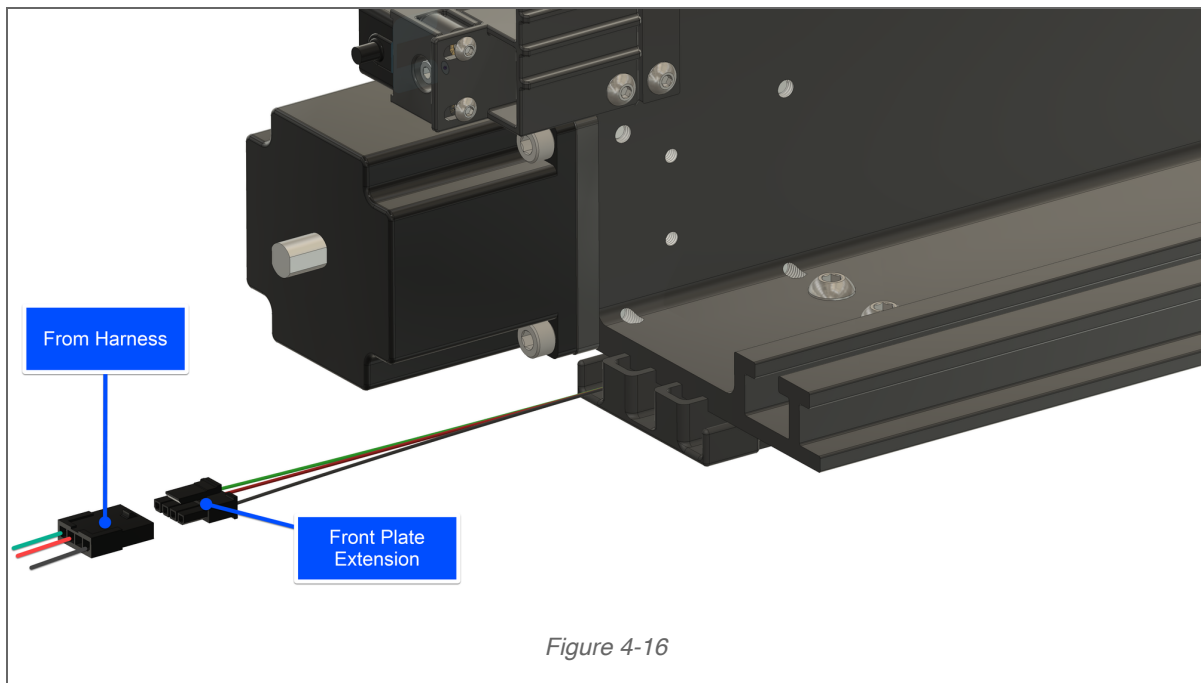

1. Locate the single-row 4-pin connector coming from the Harness
2. Plug the Front Plate extension into the 4-pin connector.

## 5.5 Install YR Wire Keeper

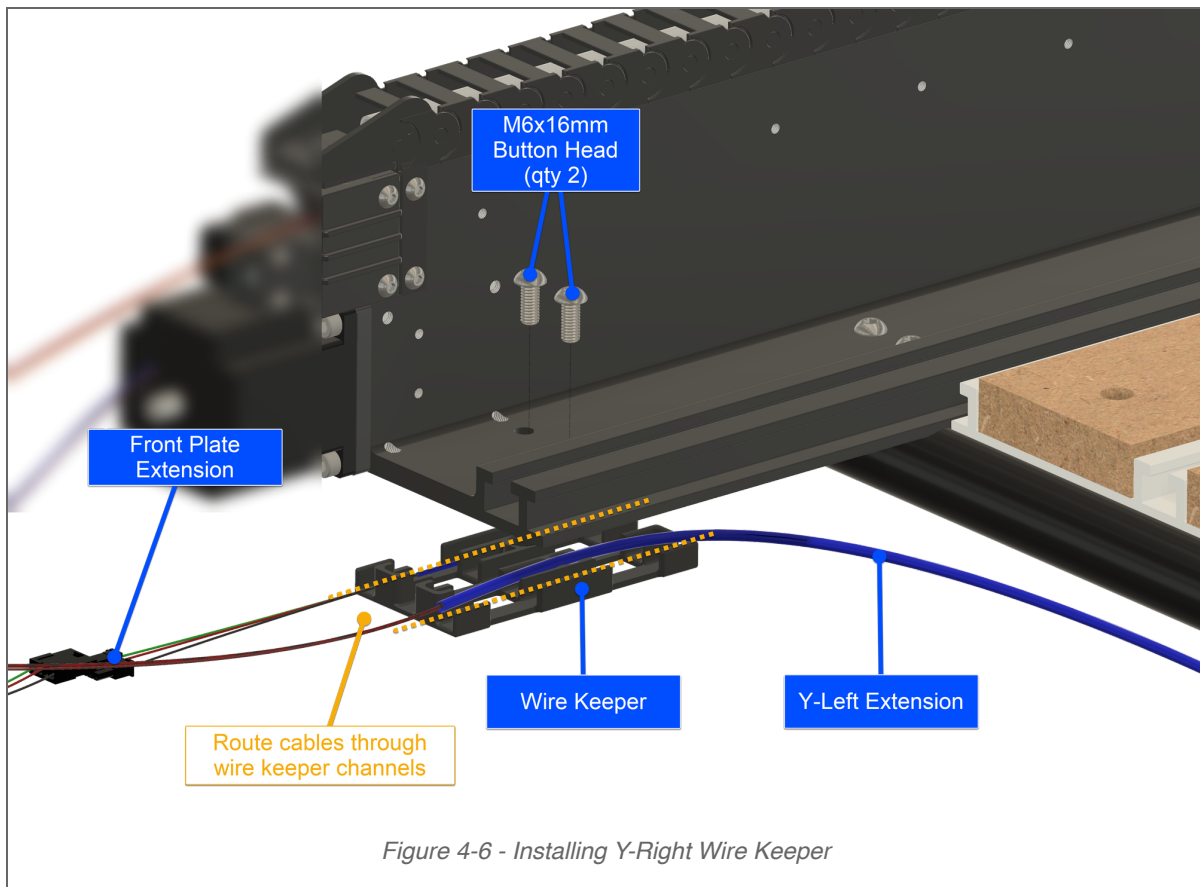

1. Use the other Wire Keeper from the *Wiring Harness Box*\* and Fig. 4-6 and Fig. 4-16 as a reference.
2. Set the **Front Plate Extension** cable into the Wire Keeper.
3. Set the Y-Left cables into the Wire Keeper.
4. Place the wire keeper under the Y-Left assembly.
5. Align the screw holes in the wire keeper with those in the assembly.
6. Use a 4mm hex key and two (2) M6x16mm BHCS to attach the wire keeper to the Y-Right assembly.  
Fully tighten.

NOTE: When securing the wire keepers, make sure all cables are seated in channels and will not be pinched/crushed when keepers are tightened.

## 5.6 Connect Y-Right Motor and Limit Cables

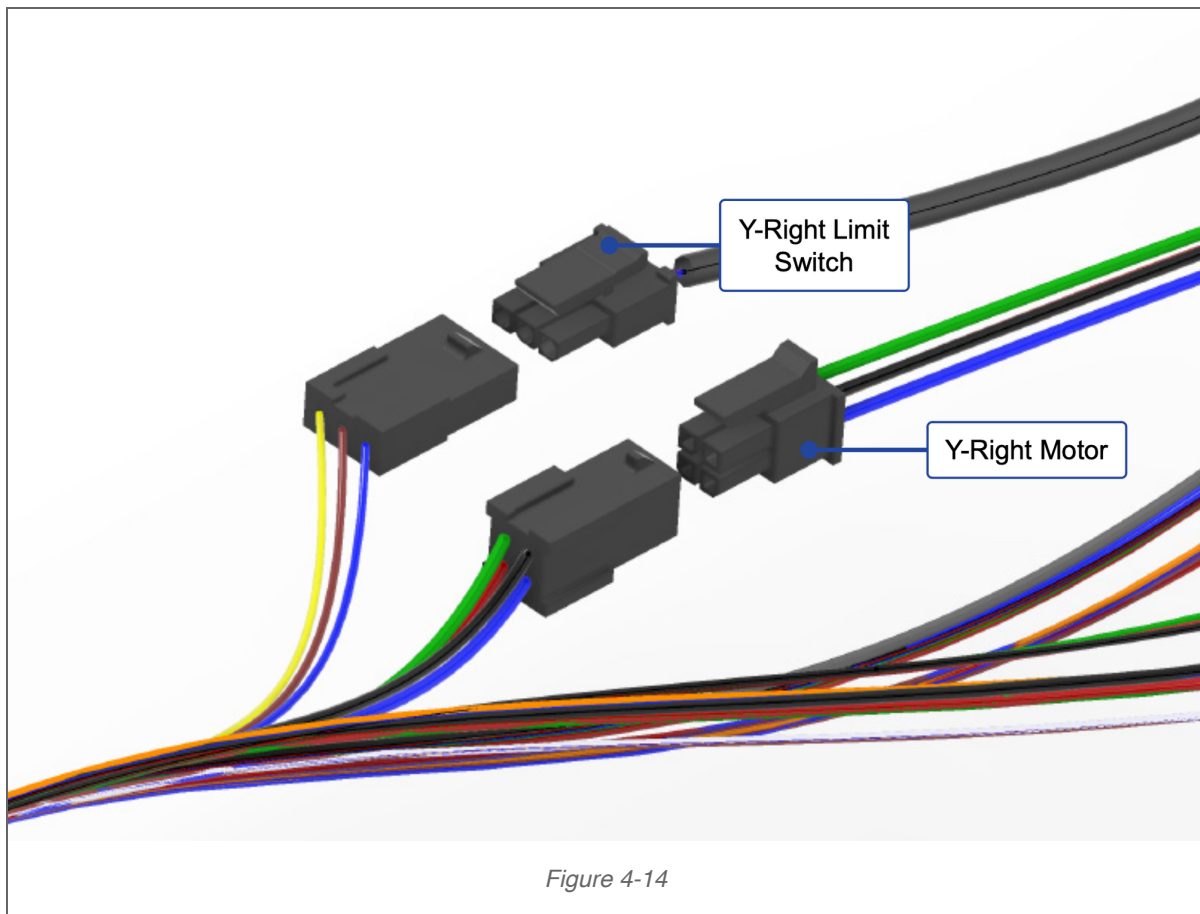

1. Move to the right side of the machine.
2. Locate the two (2) Y-Right cables (one 4-pin and one 3-pin) exiting the wiring harness trunk.
3. Connect the Y-Right stepper motor. See Fig. 4-14.
4. Connect the Y-Right limit switch. See Fig. 4-14.

## 5.7 Connect Gantry

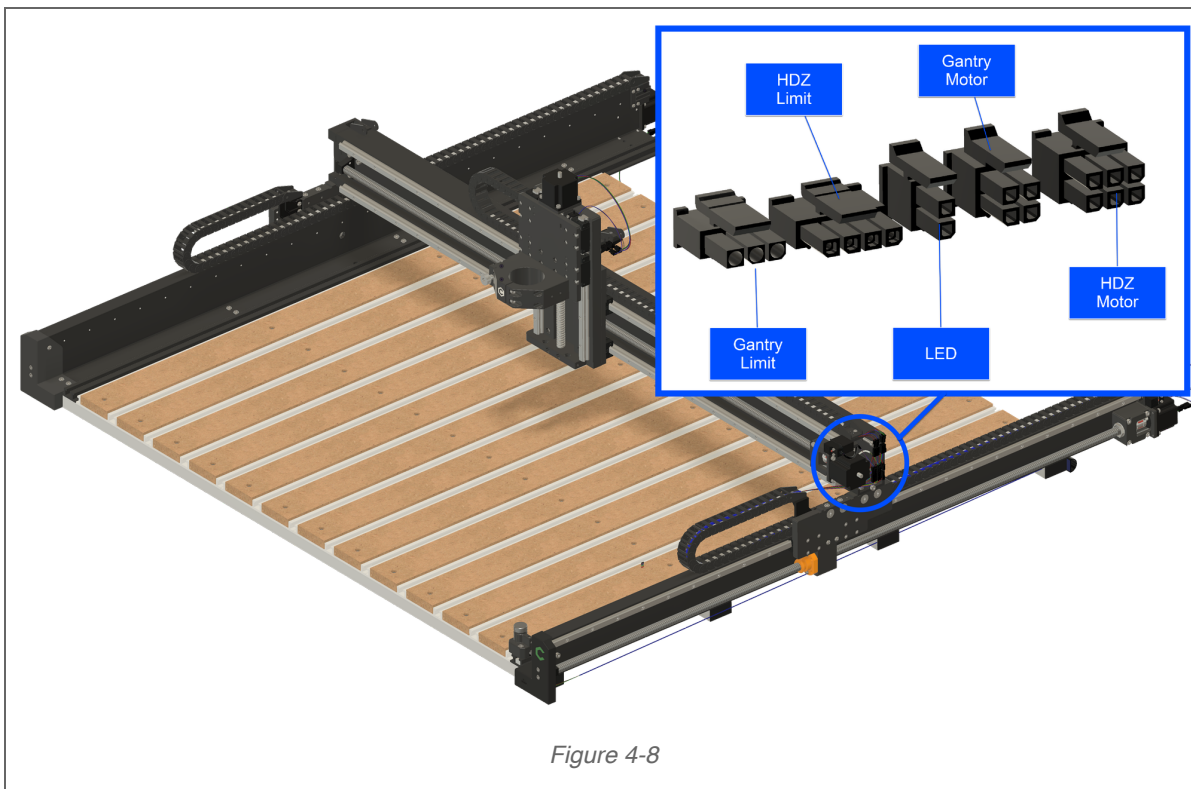

NOTE: The Harness Gantry Connection Point Consists of five (5) connectors, detailed in Fig. 4-8 and described in the table below. Each of these connectors is polarized and will only connect one way. Be sure the connectors are properly oriented with the locking tabs aligned before plugging them in. **Do not force a connection.**



Item	Description	Connector Type
HDZ Limit	Connects to HDZ Limit Extension from HDZ	1x4
HDZ Motor	Connects to HDZ Motor Extension from HDZ	2x3
Gantry Motor	Connects to Gantry Motor	2x2
Gantry Limit	Connects to Gantry Limit	1x3
LED	Connects to LED Strip	2x1

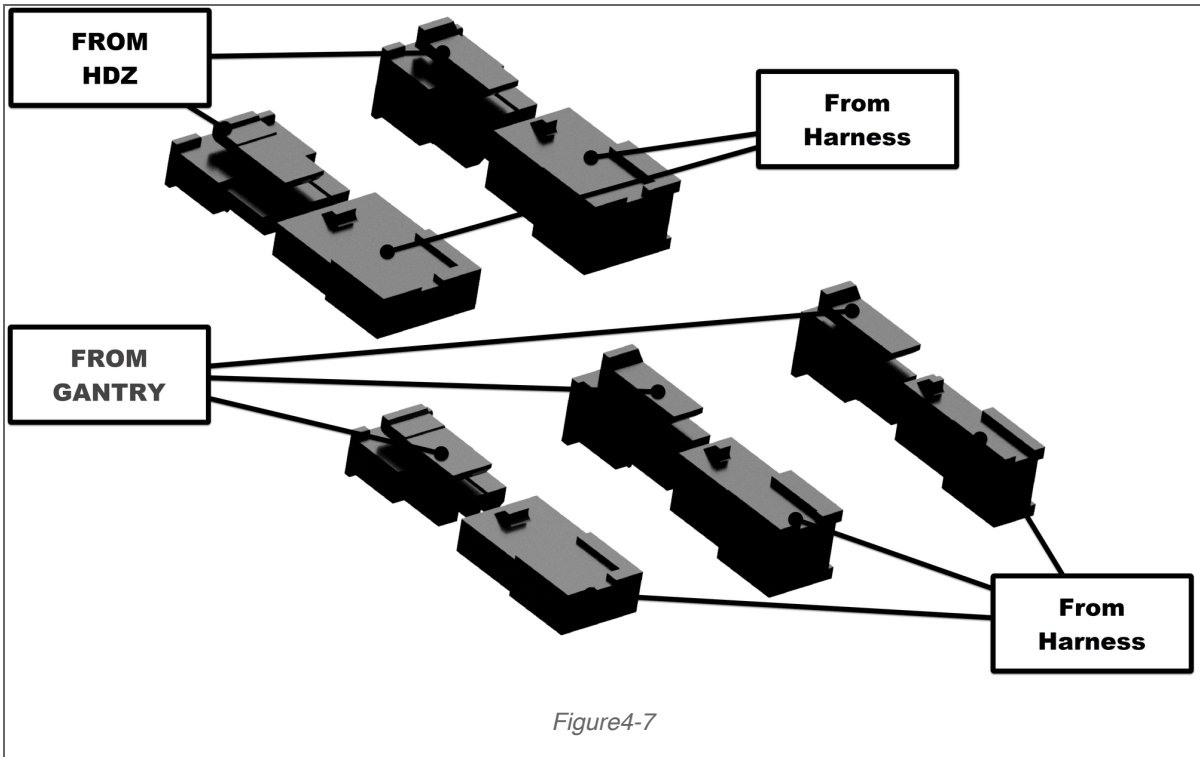

1. Move to the right side of the machine so you have clear access to the end of the gantry and the harness installed in the previous step.
2. Connect the gantry LED to the Harness using the 2-pin connector.
3. Connect the Gantry Motor to the Harness using the 4-pin dual-row connector.
4. Connect the Gantry Limit to the Harness using the 3-pin connector.
5. Connect the HDZ Motor to the Harness using the 6-pin connector.
6. Connect the HDZ Limit to the harness using the 4-pin single-row connector.

NOTE: Carefully tuck all five (5) of the cables you just connected into the open end of the gantry. Ensure the cables are not pinched or bent at extreme angles.

## 5.8 Install Y-Right End Cap

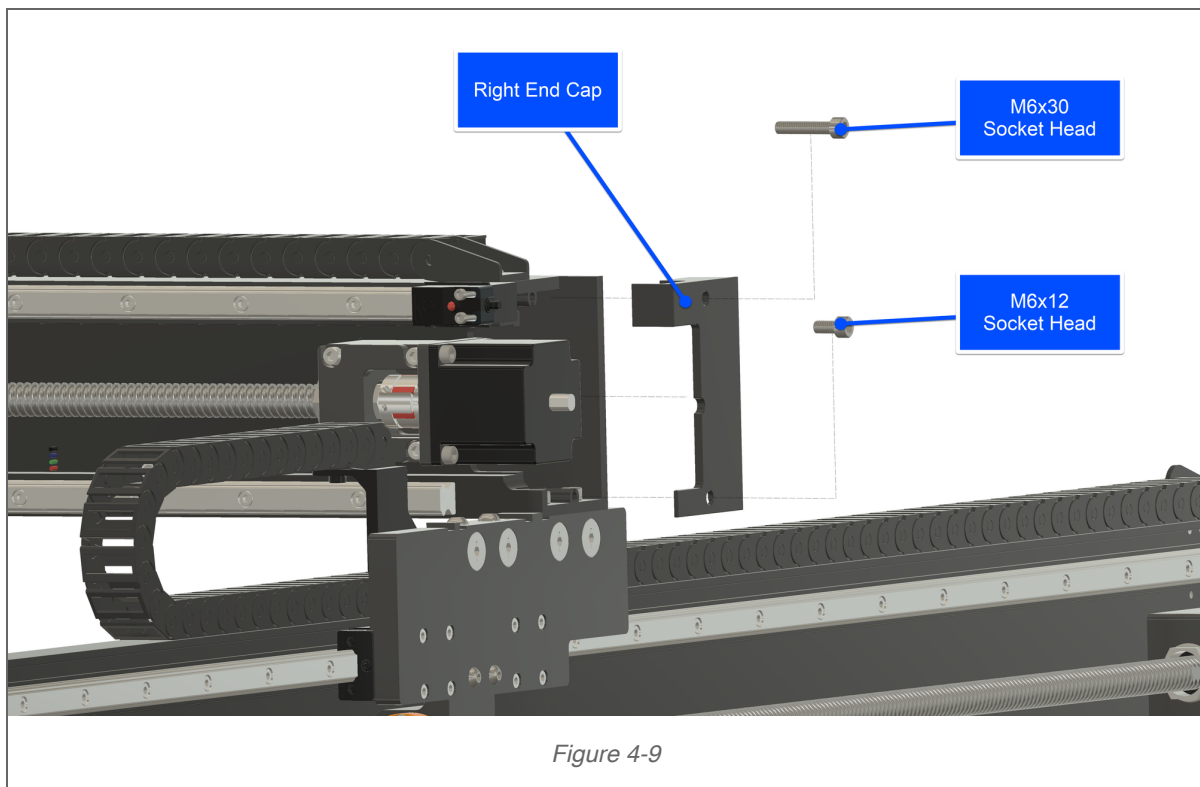

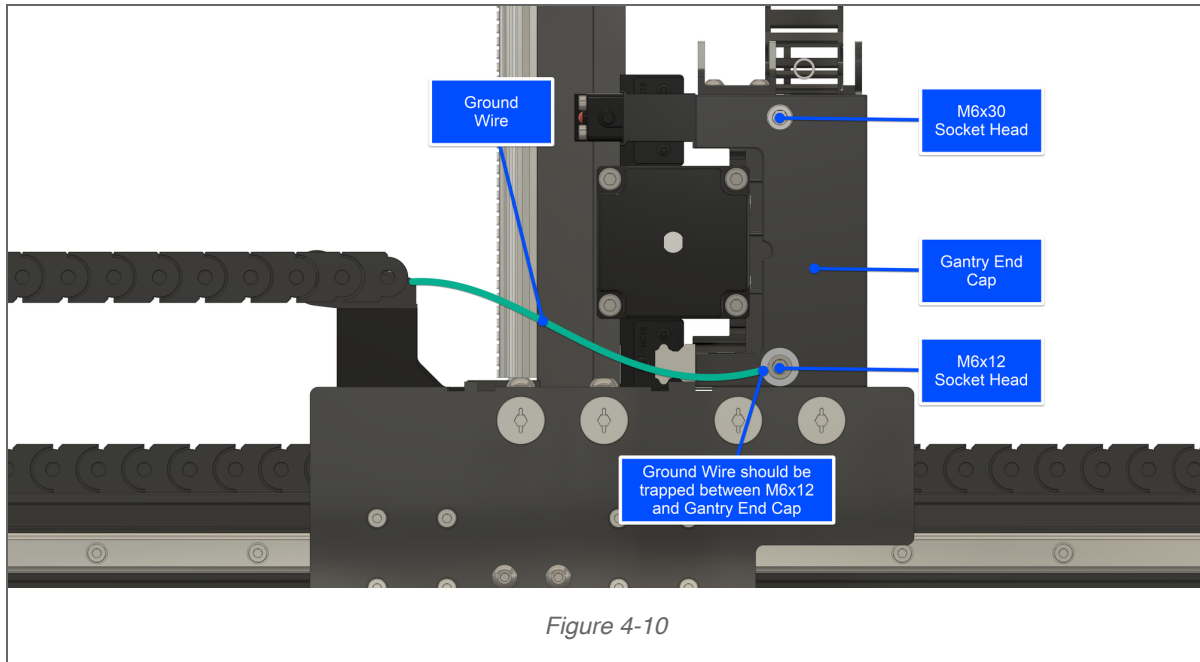
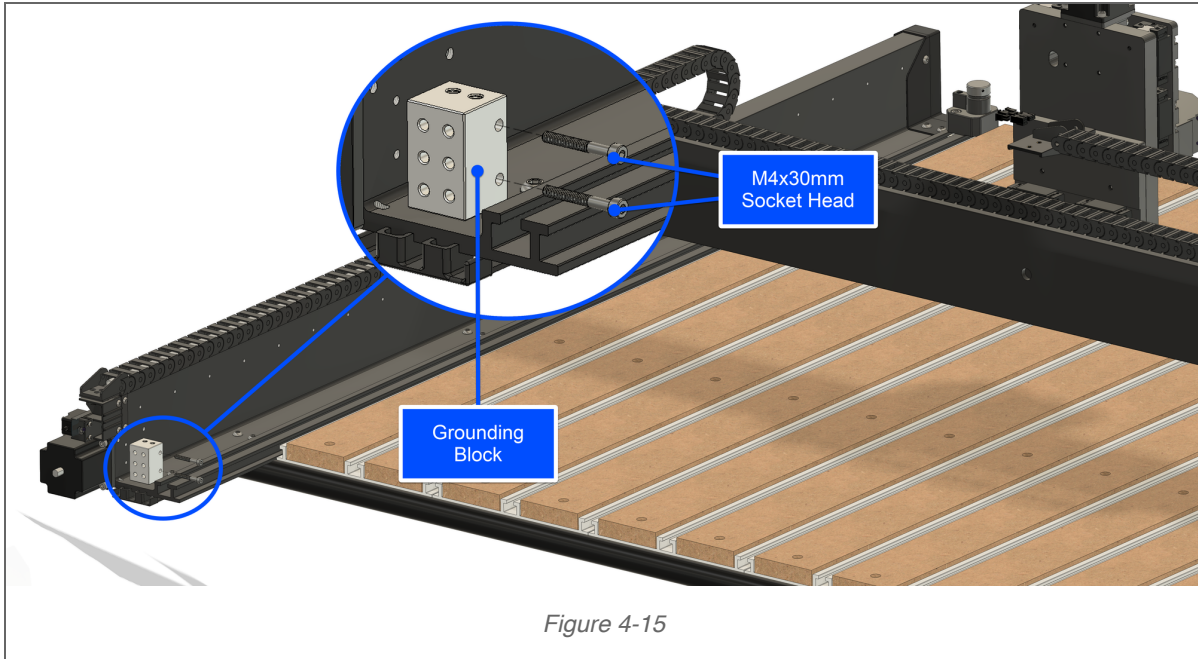

Figure 4-10

1. Gather the Right End Cap and hardware (one M6×30mm and one M6×12mm SHCS).
2. Make sure the gantry wiring is tucked into the cavity in the Gantry.
3. Place the Right End Cap on the End of the Gantry. See Figure4-9.
4. Use a 5mm hex key to insert one (1) M6×30mm SHCS through the top screw hole.
5. Locate the green and yellow grounding wire exiting the wiring harness at the Gantry.
6. Place the loop at the end of the grounding wire onto the end of the M6×12mm SHCS. See Figure4-10.
7. Use a 5mm hex key to insert the M6×12mm SHCS through the bottom screw hole in the end cap. See Figs. 4-9 and Fig. 4-10.

## 5.9 Install Grounding Block



1. Locate the grounding block and its hardware in the Grounding Block bag.
2. Position the grounding block on the inside of the Y-Right assembly, at the rear. See Fig. 4-15.
3. Rotate the grounding block so the six (6) non-threaded holes face the rear and the two (2) threaded holes face up.
4. Use a 3mm hex key and two (2) M4x30mm BHCS to attach the grounding block to the inside of the Y-Right assembly. See Fig. 4-15.
5. Locate the green and yellow cable with the banana plug exiting the wiring harness.
6. Insert the banana plug into any of the six (6) non-threaded holes on the rear face of the grounding block.

## 6. Spindle / Router

Items Required	Qty
X- and Y-Axis Router Drag Chains	2
Router / Spindle (Optional Purchase)	1
Drag Chain Hardware: M3×6mm SHCS (6); M4×6mm BHCS (2)	1
Y-Left End Cap	1
Top End Cap Hardware: M6×30mm Socket Head Cap Screw	1
Bottom End Cap Hardware: M6×12mm Socket Head Cap Screw	1

### 6.1 Preparing the Router Drag Chains

1. Locate the two (2) empty router drag chains in the **Wiring Harness Box**.
2. Lay the drag chains flat, hinge-side up, side by side on the baseframe. See Fig. 5-1.
3. Use a large hex key or long flathead screwdriver to pry open the link hinges on both drag chains.
4. Use a flathead screwdriver to pry the head link and tail link off each drag chain and set them aside.

## 6.2 Insert Power Cable

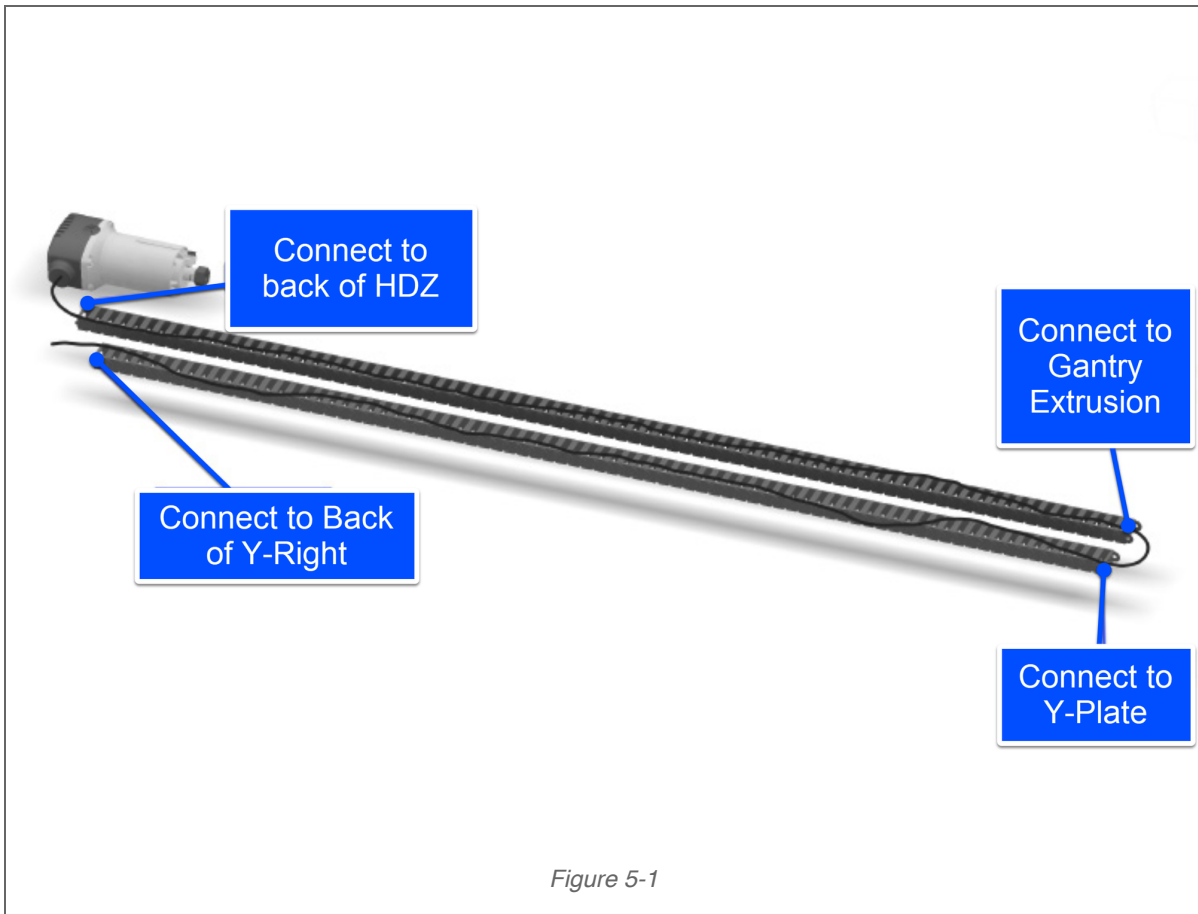

1. Place the router at the end of one drag chain.
2. Lay the router power cable in the drag chain and close the first and last links to hold the cable in place.
3. Lay the power cable into the other drag chain
4. Close the first and last links of the other chain to hold the cable in place.
5. Snap closed the remaining links in both drag chains.
6. Snap the head and tail links back onto both drag chains.

NOTE: When installing the drag chains, if a head or tail link is upside down, simply pry it off with a small screwdriver and reattach it, flat side to the rail.

### 6.3 Install the Drag Chains

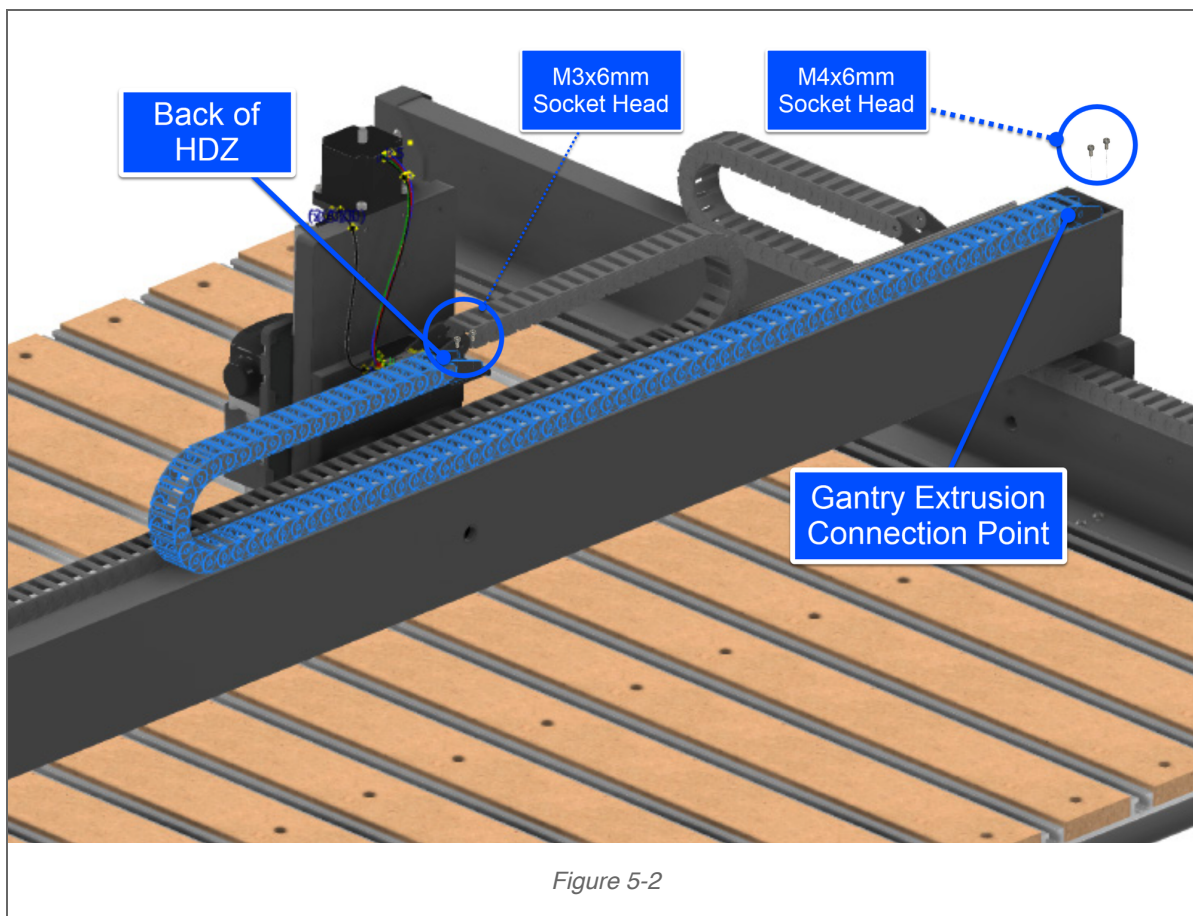

1. Lift the drag chains and router and move them to the front of the machine.
2. Insert the router/spindle as far as it will go into the spindle mount on the front of the HDZ.
3. Lift the spindle drag chain over the HDZ and set it on top of the gantry. See Fig. 5-2.
4. Lift the Y-Axis (shorter) drag chain and set it onto the Y-Left assembly (it slides under the gantry).  
See Fig. 5-3.
5. Use a 2.5mm hex key and two (2) M3×6mm SHCS to secure the drag chain to the bracket on the back of the HDZ. Fully tighten.
6. Use a 2.5mm hex key and two (2) M4×6mm BHCS to secure the drag chain to the end of the gantry.  
Fully tighten.
7. Use a 2.5mm hex key and two (2) M3×6mm SHCS to secure the drag chain to the Y-Left carriage.  
Fully tighten.
8. Use a 2.5mm hex key and two (2) M3×6mm SHCS to secure the Y-Axis drag chain tail to the Y-Left assembly. Fully tighten.



## 6.4 Secure Router & Cable

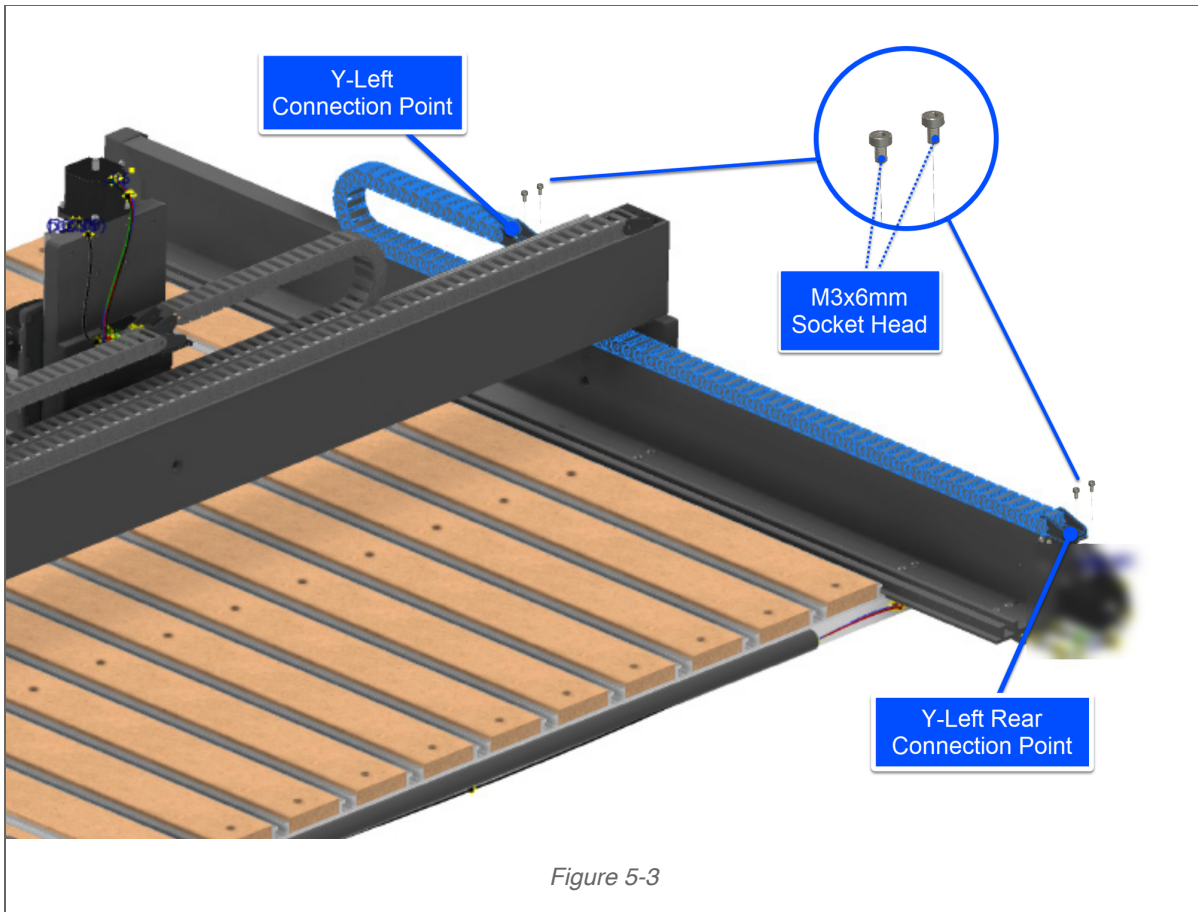

1. Orient the router in the spindle mount so that the power cable extends toward Y-Left.
2. Use a 5mm hex key to tighten the four (4) M6 screws, securing the router in the spindle mount.
3. Push the HDZ down to the bottom of travel.
4. Use a zip tie to secure the router power cable to the head end of the X-Axis router drag chain.
5. Use a zip tie to secure the router power cable to the tail end of the X-Axis router drag chain.

NOTE: Make sure there is enough power cable to allow the HDZ to move freely and to prevent binding during travel.

## 6.5 Install Y-Left End Cap

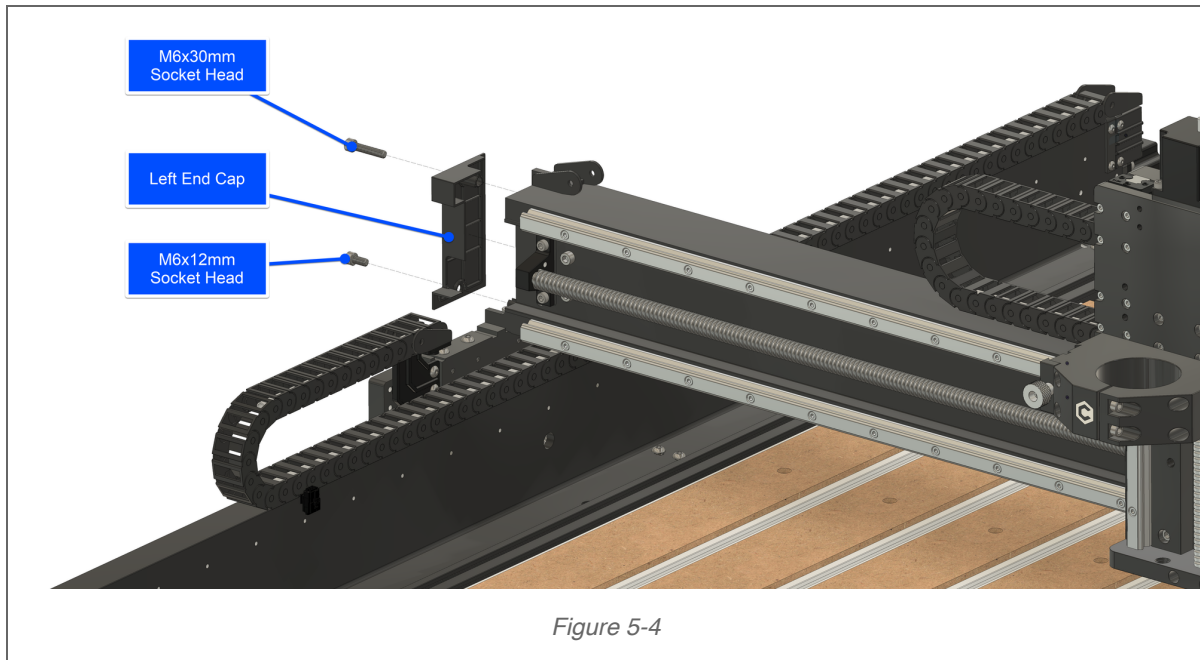

1. Gather the Y-Left End Cap and Hardware (one M6×30mm SHCS and one M6×12mm SHCS).
2. Route the router power cable down over the edge of the gantry.
3. Place the end cap over the Y-Left end of the gantry and the power cable.
4. Ensure that the long straight edge goes to the back.
5. Use a 5mm hex key to insert one (1) M6×30mm SHCS through the top screw hole and one (1) M6×12mm SHCS through the bottom screw hole.

## 7. Controller and Bitsetter

Items Required	Qty
Controller	1
Power Pendant	1
Power Pendant Extension Cable (8-pin Male to 6-pin Male)	1
3-Prong Controller Power Cable	1
USB Cable	1
BitSetter	1
BitSetter Hardware: M6×30mm (2) and Teez Nuts (2)	1
BitSetter Extension Cable (3-pin Male to 3-pin Male)	1

## 7.1 Connect the Controller

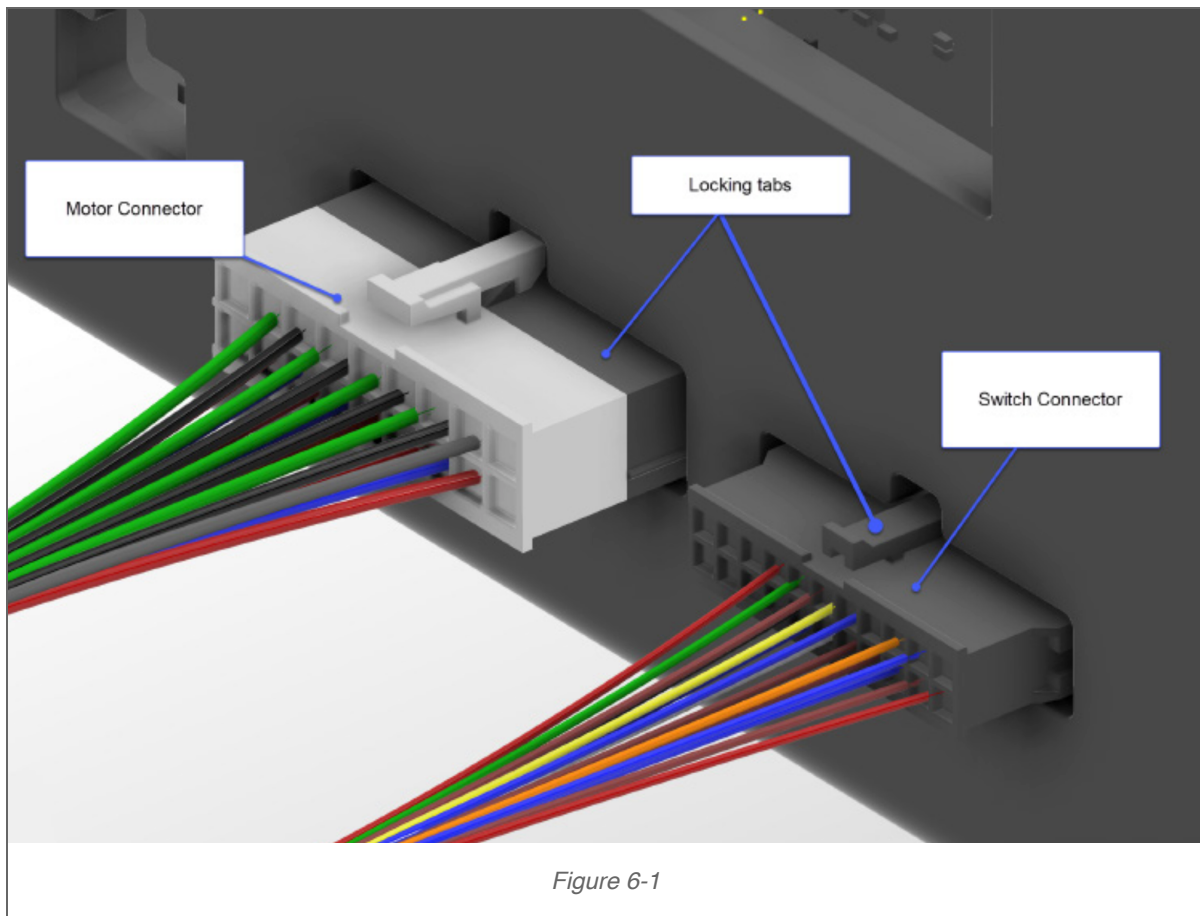

1. Locate the Controller box, Power Pendant box, and USB cable in the S5 Electronics Box.
2. Plug the 18-pin motor wiring bundle connector into the larger 18-pin **“MOTORS”** port on the controller. See Fig. 6-1.
3. Plug the 22-pin limit switch wiring bundle connector into the smaller 22-pin **“SWITCHES”** port on the controller. See Fig. 6-1.
4. Plug the 8-pin end of the power pendant cable into the port labeled **“POWER PENDANT”** on the controller.
5. Plug the 6-pin end of the power pendant cable into the power pendant. Be sure to align the locking tabs for proper orientation.
6. Plug the USB cable into the port labeled **“USB”**.
7. Plug the 3-prong power cable into the power jack on the side of the controller.

## 7.2 Install the BitSetter

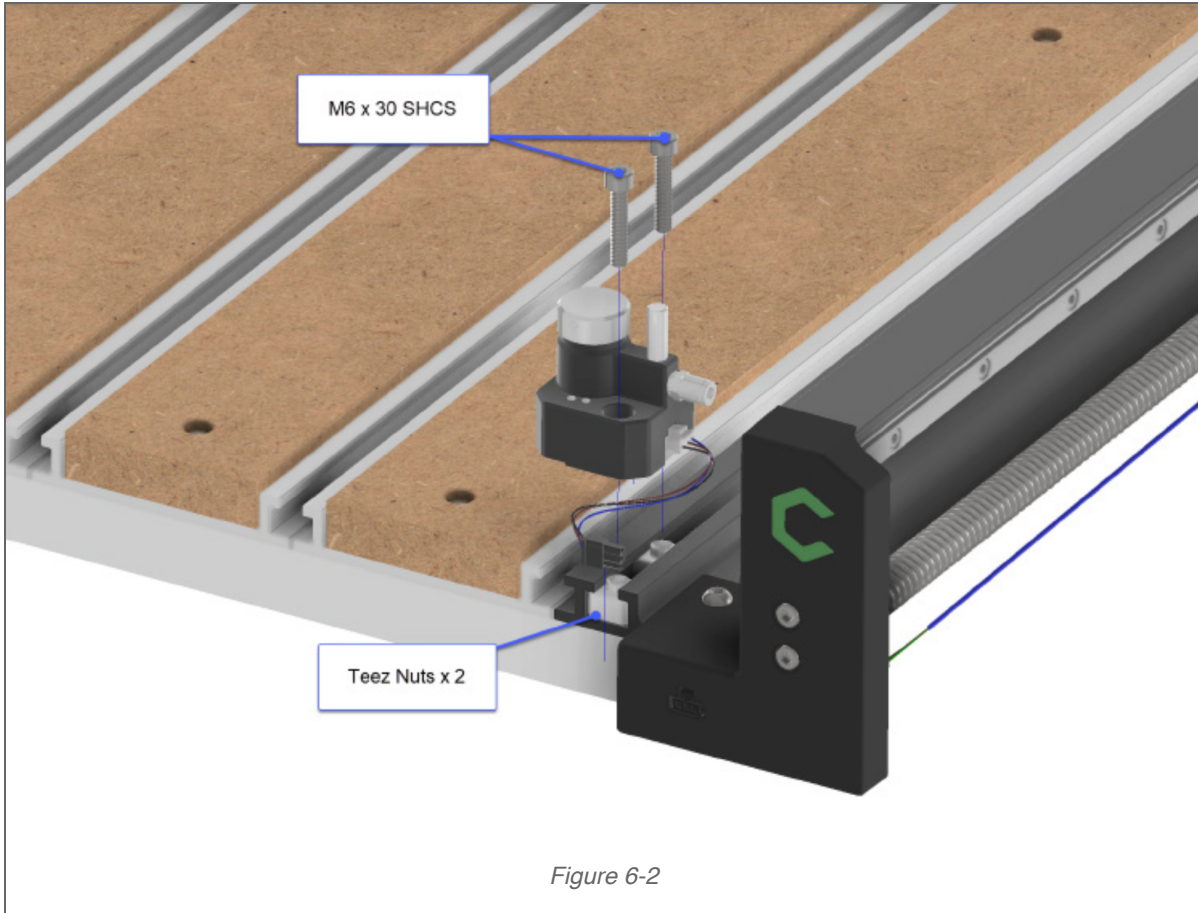

1. Locate the **BitSetter Box** in the S5 Electronics Box.
2. Slide the two (2) Teez Nuts into the T-track slot integrated into the Y-Right assembly. See Fig. 6-2.
3. Position the BitSetter over the Teez Nuts with the 3-pin port on the base facing to the right.
4. Use a 5mm hex key to loosely insert two (2) M6x30mm SHCS through the top of the BitSetter and into the Teez Nuts. See Fig. 6-3.
5. Slide the BitSetter close to the front edge of the baseframe. Fully tighten the SHCS.
6. Plug the short 3-pin BitSetter extension cable into the 3-pin port on the inside edge of the front-right endplate. See figs. 6-2 and 6-3.
7. Plug the other end of the 3-pin extension cable into the 3-pin port on the BitSetter. See Fig. 6-3.

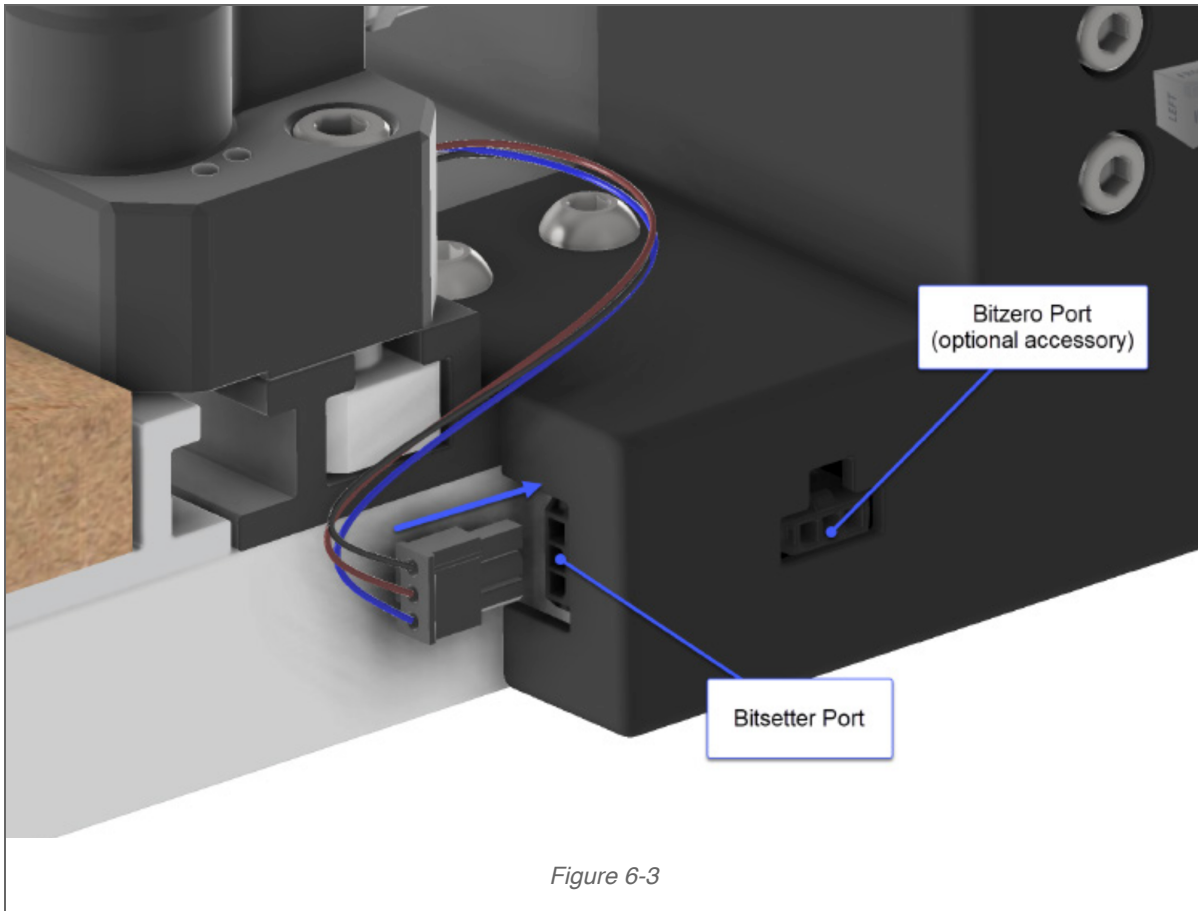

Figure 6-3

### 7.3 Tidy Up

1. Locate the zip ties and self-adhesive cable ties in the Open Me First Box.
2. Use a self-adhesive cable tie and a zip tie to tidy the Y-Left cables at the back of the machine.
3. If needed, readjust the reusable velcro strapping attached to the wiring harness trunk to tidy the wiring harness cables.

Congratulations, the Shapeoko 5 Pro assembly is complete!

**IMPORTANT:** Before homing your machine, you **MUST** update your machine configuration settings. See the Shapeoko 5 Pro Getting Started Guide for detailed instructions.

<https://my.carbide3d.com/docs/shapeoko-setup/>

## 8. Where to go next

### 8.1 Machine Configuration

For the latest instructions on how to configure your machine, see the <https://my.carbide3d.com/docs/shapeoko-setup/>.

### 8.2 Training

Access training videos, design resources, and more at [my.carbide3d.com](https://my.carbide3d.com).

Your Shapeoko 5 Pro comes with four 30-minute 1-on-1 training sessions with a Carbide 3D expert via video chat that can be used in the first year of ownership. To schedule your training sessions, visit <https://carbide3d.com/schedule/>.

### 8.3 Support and Warranty

#### Technical Support

Have questions? Need help? We have a fully-staffed support team waiting to help if you run into any trouble while assembling your Shapeoko 5 Pro. Just email us at [support@carbide3d.com](mailto:support@carbide3d.com).

#### One-Year Warranty

Your Shapeoko 5 Pro comes with a one-year warranty against defects. If you have any problems, we'll take care of them. See the full warranty at <https://carbide3d.com/policy/warranty>.

#### 60-Day, “Mistakes Are on Us” Guarantee

We want you to jump into your new Shapeoko CNC router without any fear of damaging anything so our warranty includes the following benefit: for the first 60 days that you own your Shapeoko, we'll replace any Carbide 3D-branded item that's damaged, even if it's your fault. Details about what's covered can be found at <https://carbide3d.com/policy/mistakes/>.

## 8.4 Changes

- 1/1/2024 - Initial release of this manual in a new format.
- 1/18/2024 - Make naming conventions more consistent. Remove extra steps where possible.

## 8.5 Contact Us

### **Carbide 3D LLC**

3630 Skypark Drive Torrance, CA 90505

310-504-3637

[support@carbide3d.com](mailto:support@carbide3d.com)

[facebook.com/carbide3d](https://facebook.com/carbide3d)

[instagram.com/carbide3d](https://instagram.com/carbide3d)