

SHAPEOKO 5 PRO

CNC ROUTER

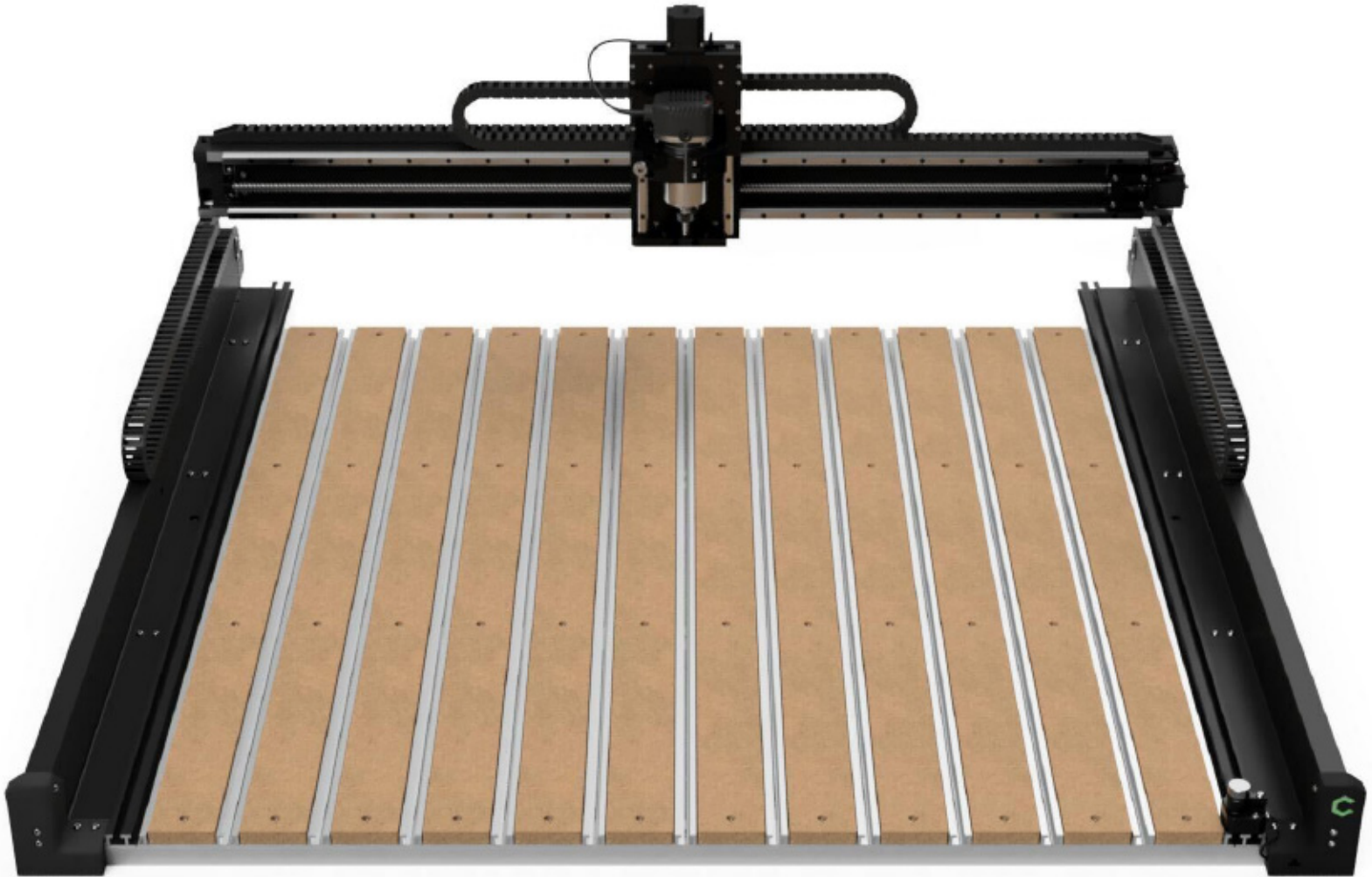

Table of Contents

| | |
|---|-----------|
| WELCOME AND CONGRATULATIONS | 2 |
| INVENTORY | 3 |
| STEP 1 | 4 |
| 1.1 Unpack Box 1..... | 5 |
| 1.2 Position Baseframe..... | 5 |
| 1.3 Install Y-Right Assembly..... | 6 |
| 1.4 Install Y-Left Assembly..... | 7 |
| 1.5 Install the Cable Track..... | 8 |
| 1.6 Prepare for Gantry Install..... | 8 |
| 1.7 Open Box 2..... | 9 |
| 1.8 Install Gantry Assembly..... | 9 |
| 1.9 Square the Machine..... | 11 |
| STEP 2 | 12 |
| 2.1 Install the HDZ..... | 13 |
| 2.2 Install X-Axis Stepper Motor..... | 14 |
| STEP 3 | 16 |
| 3.1 Install Extrusions..... | 17 |
| 3.2 Install MDF Strips..... | 17 |
| STEP 4 | 18 |
| 4.1 Install Wiring Harness..... | 19 |
| 4.2 Install YL Wire Keeper..... | 21 |
| 4.3 Connect Front Plate..... | 22 |
| 4.4 Install YR Wire Keeper..... | 23 |
| 4.5 Attach Cables at Y-Right..... | 24 |
| 4.6 Install Y-Right End Cap..... | 26 |
| 4.7 Connect Z-Axis Cables..... | 27 |
| 4.8 Connect Y-Left Motor and Limit Cables..... | 28 |
| 4.9 Connect Y-Right Motor and Limit Cables..... | 29 |
| 4.10 Install Grounding Block..... | 30 |
| 4.11 Connect Front Plate Extension..... | 31 |
| STEP 5 | 32 |
| 5.1 Preparing the Router Drag Chains..... | 33 |
| 5.2 Insert Power Cable..... | 33 |
| 5.3 Install the Drag Chains..... | 34 |
| 5.4 Secure Router & Cable..... | 35 |
| 5.5 Install Y-Left End Cap..... | 35 |
| STEP 6 | 36 |
| 6.1 Connect the Controller..... | 37 |
| 6.2 Install the BitSetter..... | 38 |
| 6.3 Tidy Up..... | 39 |

Welcome and Congratulations

The Shapeoko 5 Pro is a high-performance CNC router that comes with everything you need to accurately cut wood, plastic, and aluminum, so you can turn your workbench into a business. At up to 4 feet in width, Shapeoko 5 Pro is bigger than ever, so you can take on larger jobs or nest more parts together and run the machine longer. It's not just a CNC router, it's a complete system of hardware, software, accessories, and training, built and supported in the USA.

Assembly Notes

- We'll walk you through the assembly process step-by-step in this guide. Precision-machined parts and pre-assembled components, mean quicker assembly, in fewer steps!
- The use of power tools is not recommended for assembly. Use hand tools only.
- Some steps rely on non-tightened fasteners. Do not tighten fasteners beyond finger-tight until instructed.
- See the Glossary of Terms at the end of this guide for common CNC terms and definitions.
- Your Shapeoko 5 Pro gantry is powered by stepper motors. When the power is off, moving the motors by hand will cause them to generate electricity. **IMPORTANT:** When moving the gantry by hand, go slowly. The power generated by the stepper motors will feel like bumps. If the red LED on the controller lights up when moving the stepper motors, it's important to slow down because you are pushing electricity back through the board. Too much backflow could damage the controller.

Software Requirements

The Shapeoko 5 Pro controller must be used with the latest version of Carbide Motion.

Support, Warranty, and Training

Technical Support

Have questions? Need help? We have a fully-staffed support team waiting to help if you run into any trouble while assembling your Shapeoko 5 Pro. Just email us at support@carbide3d.com.

One-Year Warranty

Your Shapeoko 5 Pro comes with a one-year warranty against defects. If you have any problems, we'll take care of them. See the full warranty at carbide3d.com/policy/warranty.

30-Day, "Mistakes Are on Us" Guarantee

We want you to jump into your new Shapeoko CNC router without any fear of damaging anything so our warranty includes the following benefit: **for the first 30 days that you own your Shapeoko, we'll replace any Carbide 3D-branded item that's damaged, even if it's your fault.** Details about what's covered can be found at shop.carbide3d.com/pages/mistakes-are-on-us.

Free 1-on-1 Training Sessions

Your Shapeoko 5 Pro comes with four FREE 30-minute 1-on-1 training sessions with a Carbide 3D expert via video chat.

Training Videos and More

Access training videos, design resources, and more at my.carbide3d.com.

Inventory

Shipping Box 1 Contains

Open Me First Box

- Tool Bag
- Extra Hardware Bag
- Zip Ties & Cable Ties
- #201 0.25" Flat Endmill
- Workholding Kit
- Sweepy 65 V2.0 Box
- Sharpie

HDZ (Z-Axis) Box

- Pre-assembled HDZ (Z-Axis)
- HDZ Hardware Bag
- End Caps (Y-Left and Y-Right)
- End Cap Hardware Bag
- X-Axis Stepper Motor
- X-Axis Stepper Motor Hardware Bag

S5 Electronics Box

- Wiring Harness Box
 - Wiring Harness
 - Drag Chain Hardware Bag
 - X- and Y-Axis Router Drag Chains
 - Front Plate Extension Cable
 - Grounding Block and Hardware
- Power Pendant Box
 - Power Pendant
 - Power Pendant Extension Cable
- Controller Box
 - Controller
 - USB Cable
 - 3-prong Power Cable
- BitSetter Box
 - BitSetter
 - BitSetter Hardware
 - BitSetter Extension Cable

Y-Left Assembly

Y-Axis Assembly Hardware Bag

Y-Right Assembly

Baseframe Box

- Baseframe Members

Cable Track (Underneath Baseframe Box)

Shipping Box 2 Contains

X-Axis Gantry Assembly

Hybrid Table Extrusions and MDF Strips (Nested Together)

Hybrid Table Hardware Box

PRO TIP: Your Shapeoko 5 Pro kit has been carefully packaged by hand. If you find that you're missing hardware in any step, check the extra hardware bag included in the Open Me First Box. If you don't find what you need in the extra hardware bag, or one of your components was damaged in shipping, contact us at support@carbide3d.com and we'll ship you a replacement ASAP.

STEP 1

Baseframe and Gantry

Items Needed in Step 1

| Description | Qty |
|--|-----|
| Baseframe Members | 4 |
| Y-Right Assembly | 1 |
| Y-Left Assembly | 1 |
| Y-Axis Assembly Hardware: M6×16mm Button Head Cap Screws | 16 |
| Tool Bag | 1 |
| Cable Track | 1 |
| X-Axis Gantry Assembly | 1 |

1.1 Unpack Box 1

1. In Box 1, locate the box labeled Open Me First, remove the tool bag, and set the box aside.
2. Locate the S5 Electronics and HDZ boxes and set them aside.
3. Locate the Baseframe box between the two Y-Rails at the bottom of Box 1 and remove it.
4. Open the Baseframe box and remove the four baseframe members.

1.2 Position Baseframe

1. Position the four baseframe members horizontally across your table about 15.7 inches apart, center to center. See **Figure 1-1**.
 - a. The wire clips face to the right.
2. Open the wire clip on the end of each baseframe member.

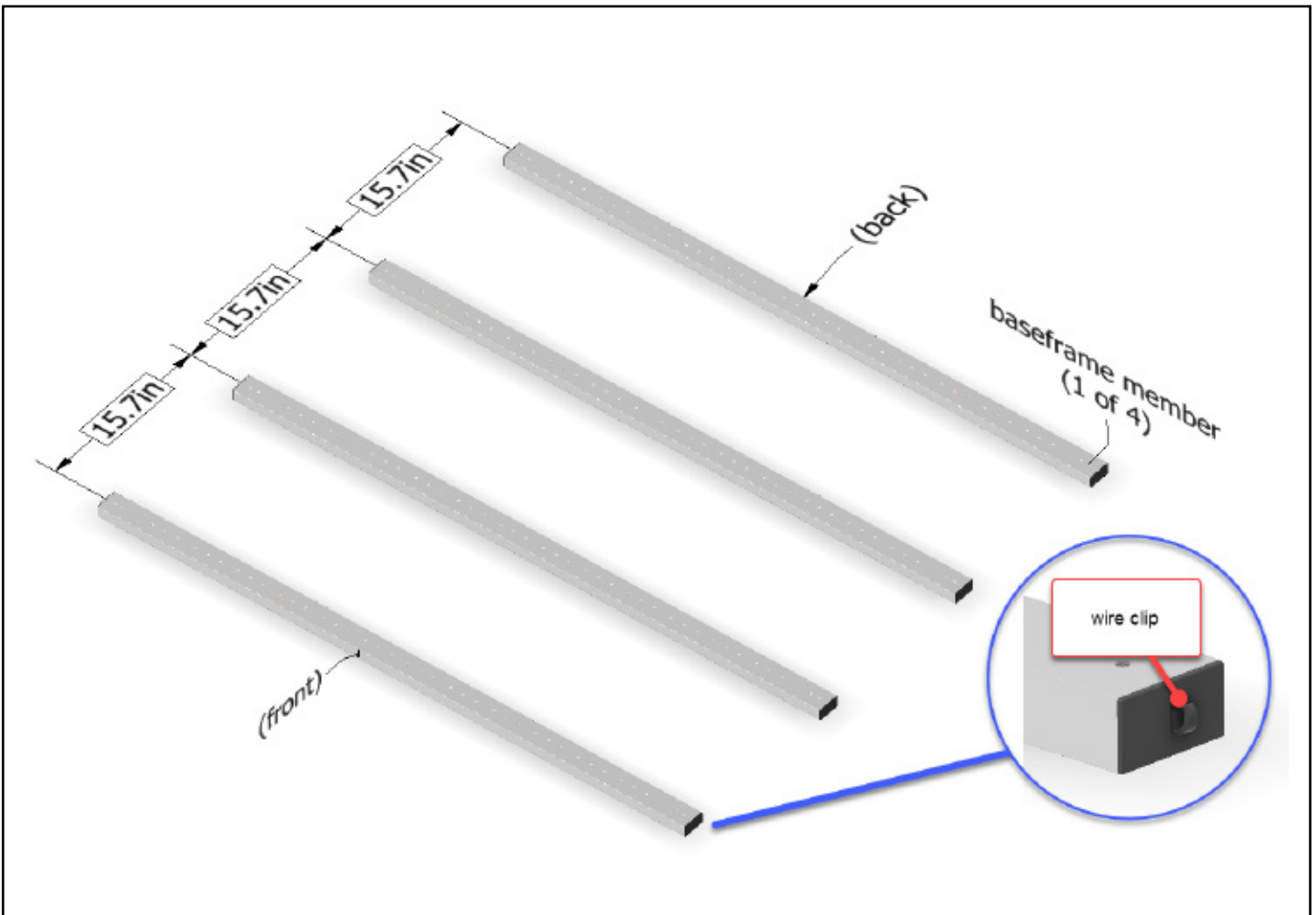

Figure 1-1

1.3 Install Y-Right Assembly

NOTE: This step is much easier with two people. The Y-assembly is heavy and can easily tip over if set upright before attaching it to the baseframe.

1. Locate the Y-Right assembly and the hardware bag in the bottom of Box 1.
 - a. Y-Right has a Carbide 3D logo on the front plate.
2. Set the Y-Right assembly on the right side of the baseframe. See Fig. 1-2.
 - a. Align the front edge with the front edge of the first baseframe member.
 - b. Align with the last set of screw holes in each baseframe member.

3. Use a 4mm hex key and eight (8) M6×16mm BHCS to attach the Y-assembly. See Fig. 1-2. Snug the screws but don't fully tighten.
 - a. Y-Right assembly is attached in four locations.
 - b. At location 1, the BHCS insert through the holes in the end cap.

NOTE: Don't worry about squaring the baseframe yet.

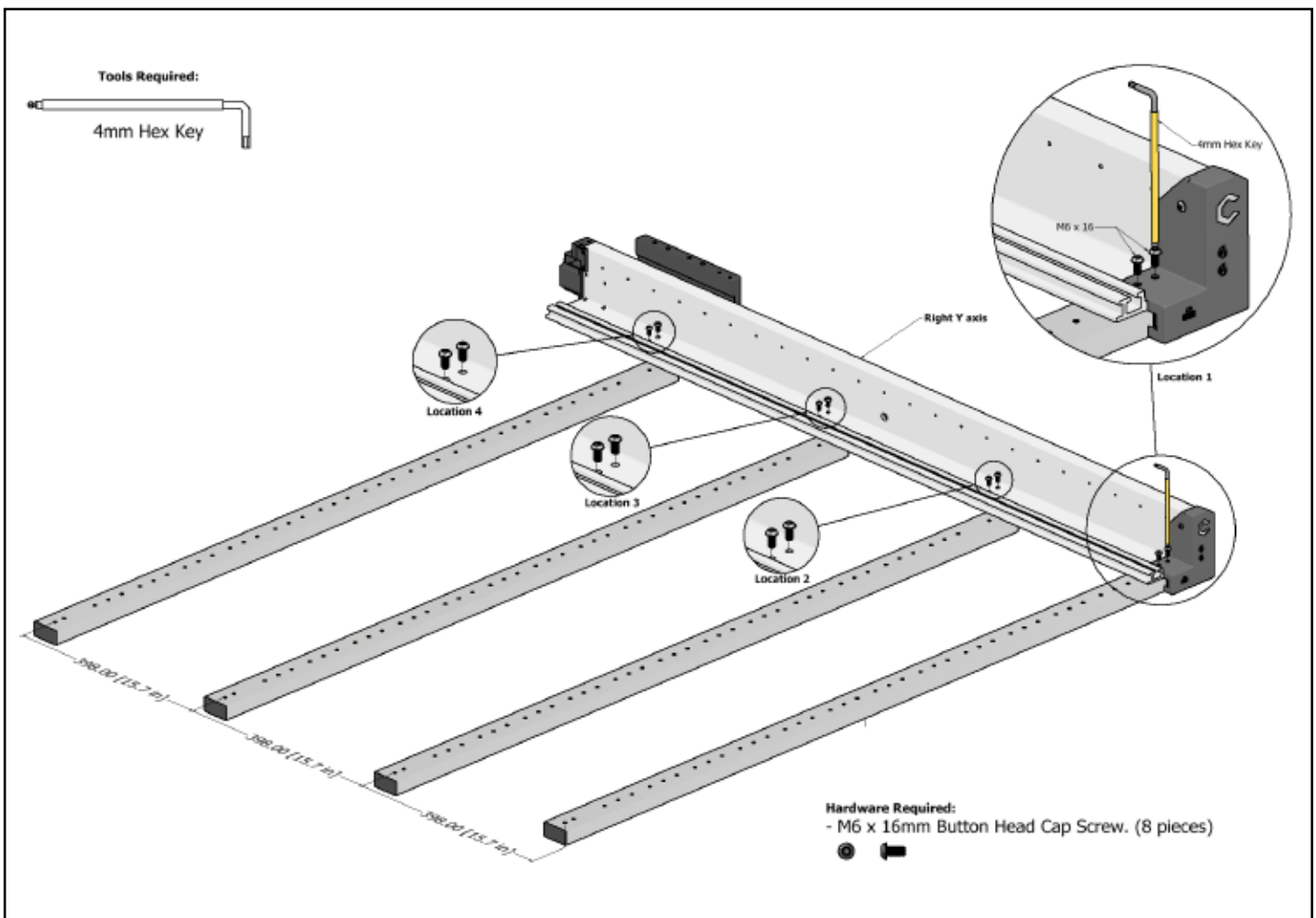

Figure 1-2

1.4 Install Y-Left Assembly

NOTE: This step is much easier with two people. The Y-assembly is heavy and can easily tip over if set upright before attaching it to the baseframe.

1. Locate the Y-Left assembly in the bottom of Box 1.
 - a. Y-Left has a blank front plate.
2. Set the Y-Left assembly on the left side of the baseframe. See **Fig. 1-3**.
 - a. Align the front edge with the front edge of the first baseframe member.
 - b. Align with the last set of screw holes in each baseframe member.

3. Use a 4mm hex key and eight (8) M6×16mm BHCS to attach the assembly. See **Fig. 1-3**. Snug the screws but don't fully tighten.
 - a. Y-Left assembly is attached in four locations.
 - b. At location 1, the BHCS insert through the holes in the end cap.

NOTE: Don't worry about squaring the baseframe yet.

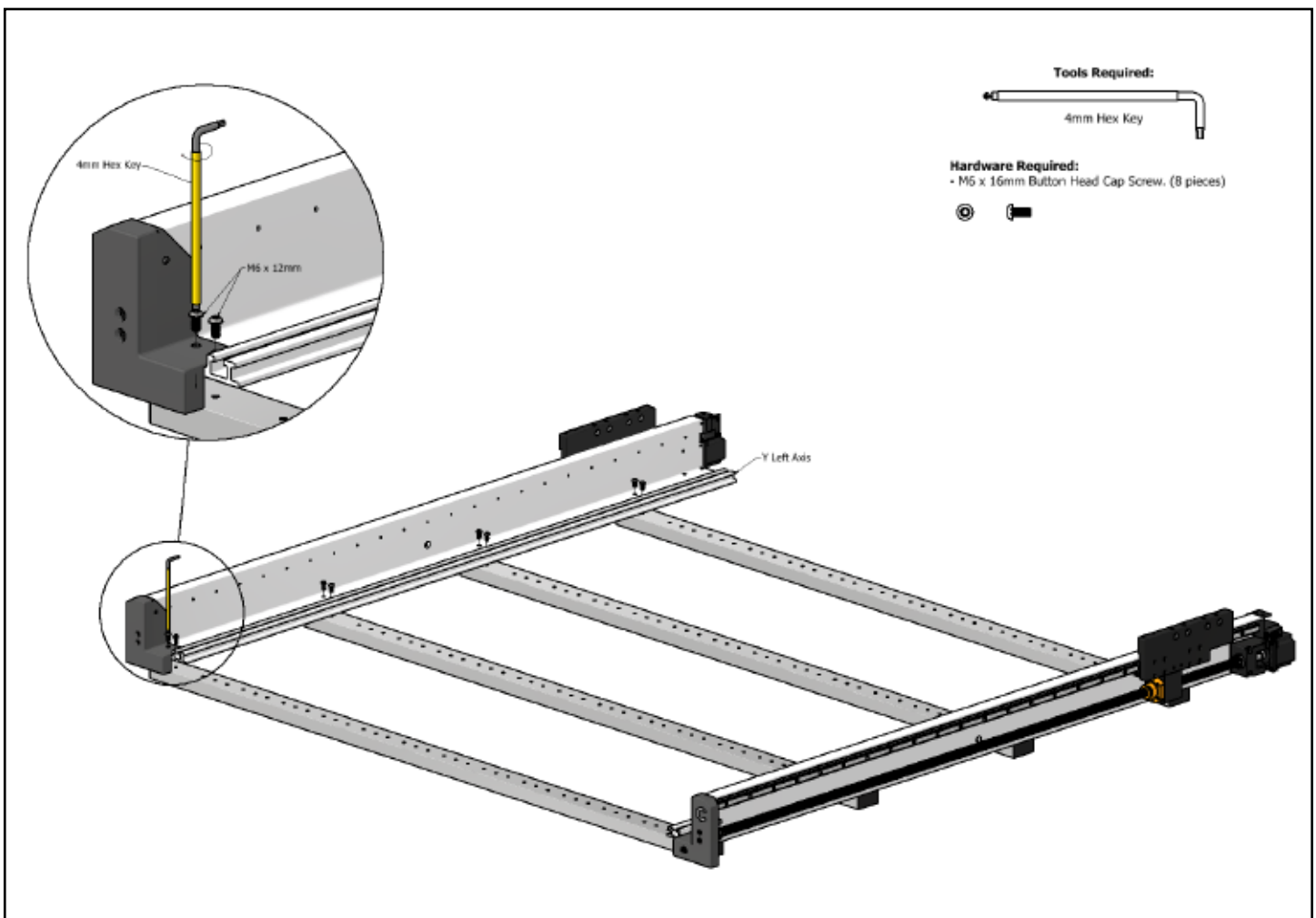

Figure 1-3

1.5 Install the Cable Track

1. Locate the cable track in the bottom of Box 1.
2. Install the cable track to the last baseframe member at the back of the machine.
 - a. Remove the protective coating.
 - b. Remove the blue adhesive cover.
 - c. Position with the opening facing up.
 - d. Align to the bottom edge of the baseframe.
 - e. Align between the two Y-Axis assemblies, there will be about 4.5 inches on either side.
 - f. From one side, press firmly as you run your hand over the entire length of the track.
3. Open the cable track.

1.6 Prepare for Gantry Install

1. Pull the Y-Right carriage all the way to the front of the machine. See **Fig. 1-4**.
2. Pull the Y-Left carriage all the way to the front.
3. Use a 5mm hex key to remove the two (2) M6×20mm SHCS from the rear position of the Y-Right and Y-Left carriages.

NOTE: Keep the M6×20mm SHCS close by. You will need them to install the gantry.

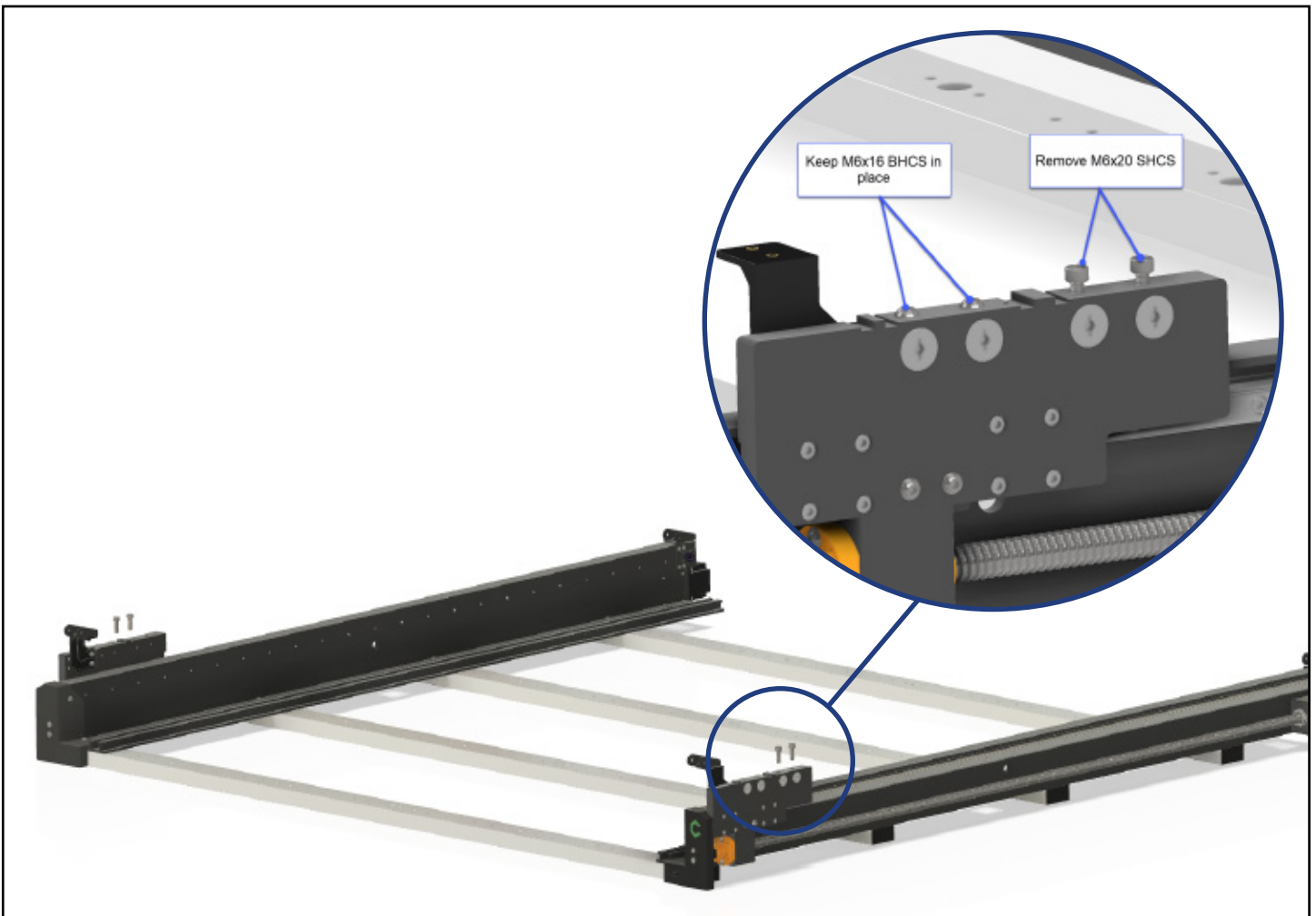

Figure 1-4

1.7 Open Box 2

1. Open Box 2. This box contains:
 - a. Shapeoko 5 Pro gantry (note that the X-Axis drag chain is pre-installed on the gantry).
 - b. Shapeoko 5 Hybrid Table (aluminum extrusions and MDF strips).
 - c. Hybrid Table hardware.

1.8 Install Gantry Assembly

NOTE: This step is much easier with two people. The X-Axis gantry assembly is heavy and can easily tip over. If the gantry tips over, the mating faces on the bottom edge will be irreparably damaged, which will prevent the gantry from attaching properly to the Y-Axis assemblies.

1. Lift the gantry from the box and set it onto the rear position of the Y-Axis carriage plates, over the now-empty screw holes. See **Fig. 1-5**.
 - a. The large X-Axis carrier plate faces the front.
2. Hold the gantry firmly in place as you complete the steps on the following page.



Figure 1-5

3. From the right side of the machine, push the gantry toward the front of the machine until it engages with the reference edge on the top of the Y-Right carriage plate. See **Fig. 1-6**.
4. Orient the cross dowels so that the reference line on the face of each is vertical. See **Fig. 1-7**.
5. Use a 5mm hex key to loosely re-insert the two (2) M6×20mm SHCS to attach the gantry to the Y-Right assembly. See **Fig. 1-7**.
6. From the left side of the machine, push the gantry forward until it engages with the reference edge on the top of the Y-Right carriage plate.

NOTE: The Y-Left extrusion is slotted. When attaching the left side of the gantry, you can slide the Y-Left extrusion inward/outward $\pm 2\text{mm}$ to align the gantry with the cross dowels.

7. Orient the cross dowels so that the reference line on the face of each is vertical. See **Fig. 1-7**.
8. Use a 5mm hex key to loosely re-insert the two (2) M6×20mm SHCS to attach the gantry.
9. Ensure the both Y-carriage plates are still in the furthest forward position.
10. Keep pressure on the gantry to keep it engaged with the reference edge on each carriage as you fully tighten all four (4) M6×20mm SHCS.

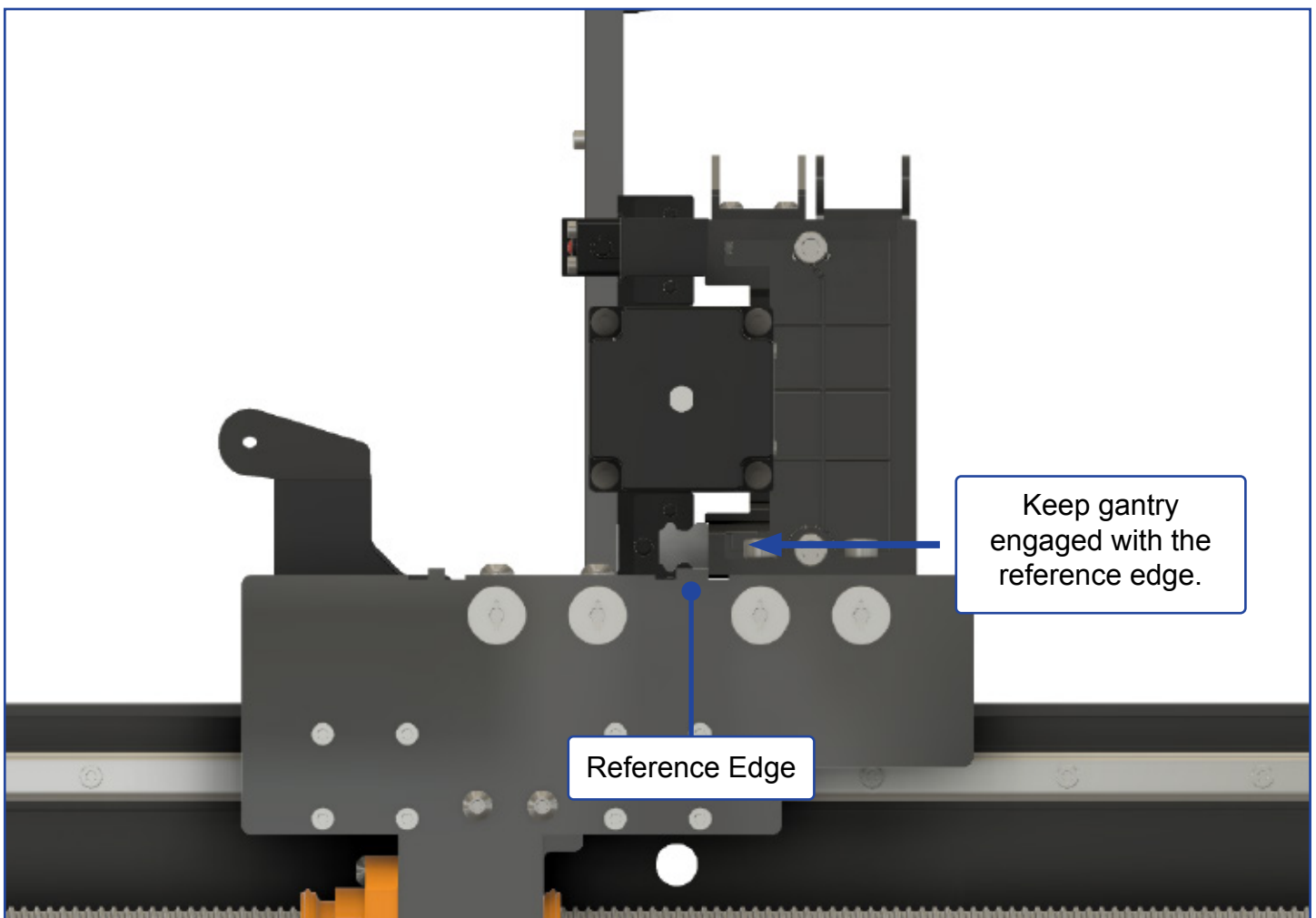

Figure 1-6

1.9 Square the Machine

1. Check that the Y-Right and Y-Left carriages are still pushed all the way to the front of the machine.
2. Starting on the right side, use a 4mm hex key to fully tighten the first pair of M6×16mm BHCS to secure the Y-Right assembly to the first baseframe member.
3. Moving to the left side, use a 4mm hex key to fully tighten the first pair of M6×16mm BHCS.
4. Push the gantry back to the second baseframe member and fully tighten the pair of screws on the right side, then on the left side.
5. Push the gantry back to the third baseframe member and tighten the screws on the right, then on the left.
6. Push the gantry all of the way to the back of the machine until it hits the Y-motor mounts and tighten the screws on the right, then on the left.

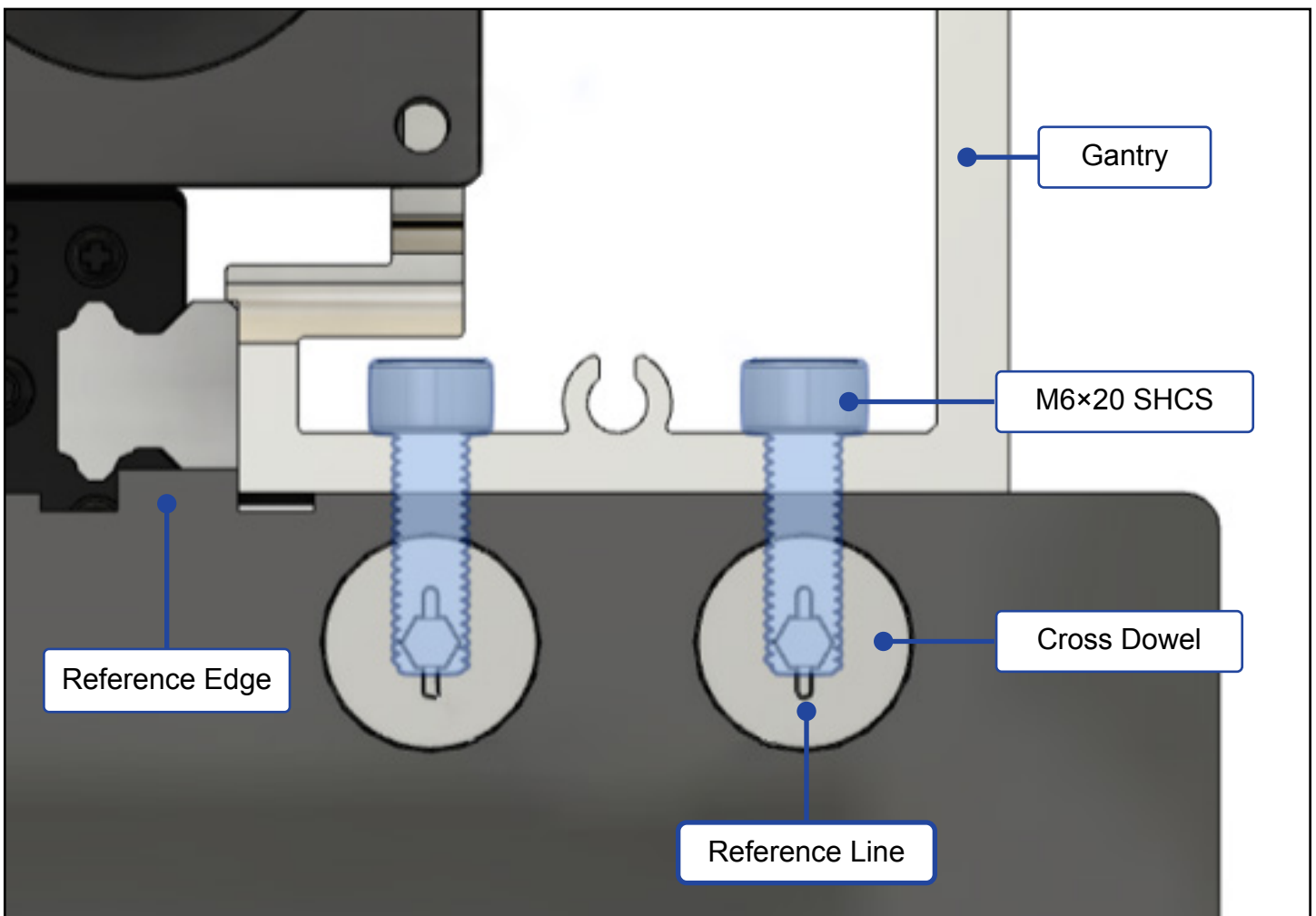

Figure 1-7

STEP 2

HDZ (Z-Axis)

Items Needed in Step 2

| Description | Qty |
|--|-----|
| HDZ (Z-Axis Assembly) | 1 |
| HDZ Hardware: M6×20mm Socket Head Cap Screws | 4 |
| X-Axis Stepper Motor | 1 |
| X-Motor Hardware: M5×10mm Socket Head Cap Screws | 4 |

2.1 Install the HDZ

1. Open the HDZ box and remove the assembled HDZ (Z-Axis Assembly), HDZ hardware, X-Axis stepper motor, X-Axis stepper motor hardware.
 2. Set the Y-Left and Y-Right end caps and hardware aside. You will not need them until STEP 4 and STEP 5.
 3. Align the HDZ with the two short locating pins on the front of the X-Axis carrier plate and push it onto the carrier plate. See Fig. 2-1.
 - a. Z-Axis stepper motor on top.
 - b. The HDZ slides onto the two locating pins. Note that it may not slide all the way onto the pins until the four SHCS are fully tightened.
 4. Hold the HDZ in place as you loosely insert four (4) M6×20mm SHCS. See Fig. 2-1.
- NOTE:** Do not let go of the HDZ until at least two of the SHCS are installed.
5. Use a 5mm hex key to fully tighten the SHCS and secure the HDZ to the carrier plate.

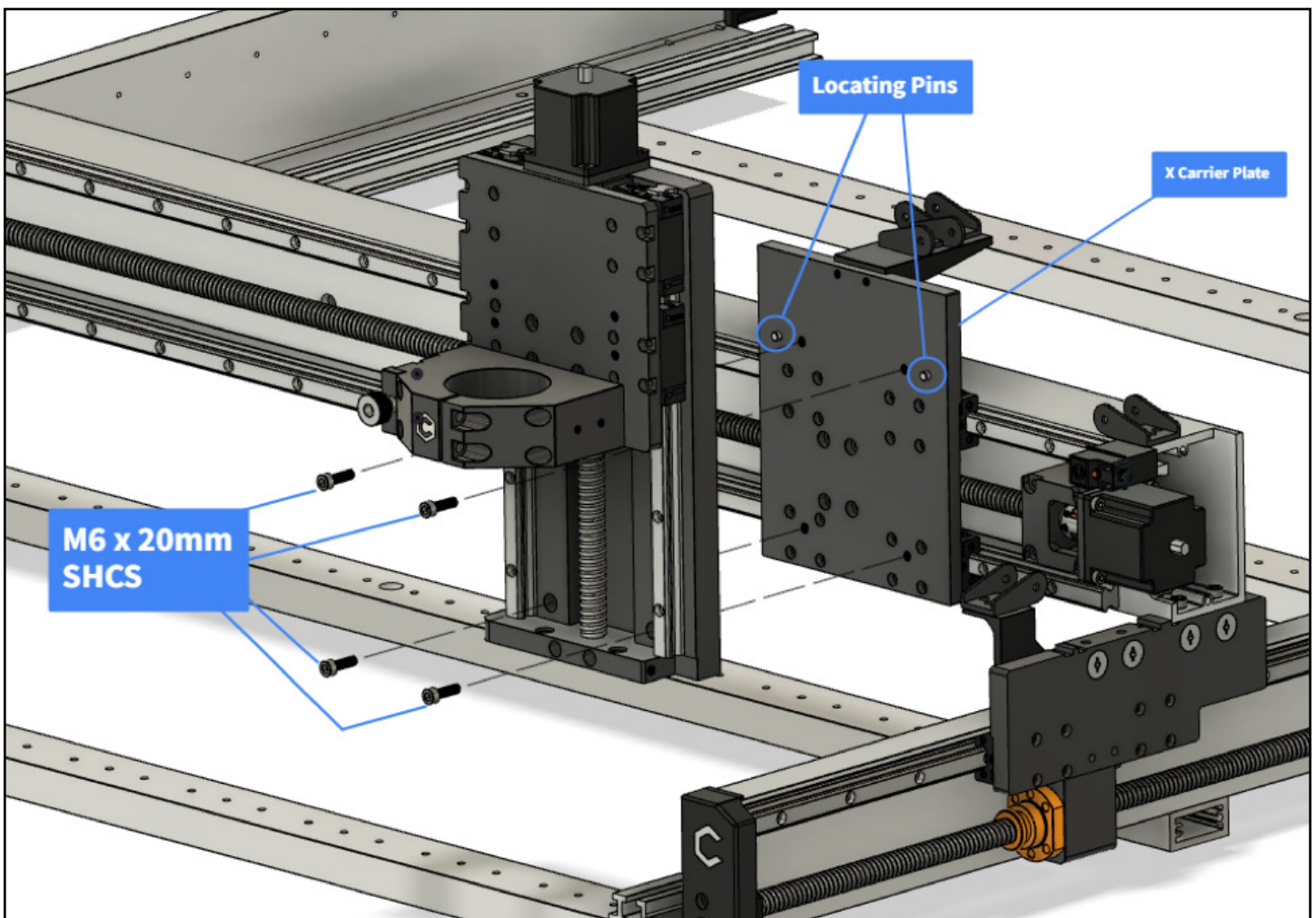

Figure 2-1

2.2 Install X-Axis Stepper Motor

1. Locate the X-motor in the HDZ box.
2. Orient the X-motor with the motor coupler facing toward the mount. See **Fig. 2-2**.
 - a. Motor wires face the rear of the machine. See **Fig. 2-3**.
3. Rotate the motor shaft until the motor coupler is lined up with the ball-screw coupler inside the mount.

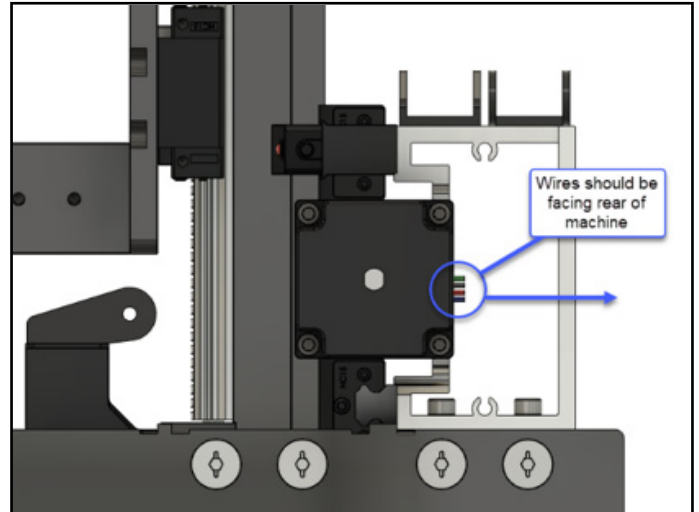

Figure 2-3

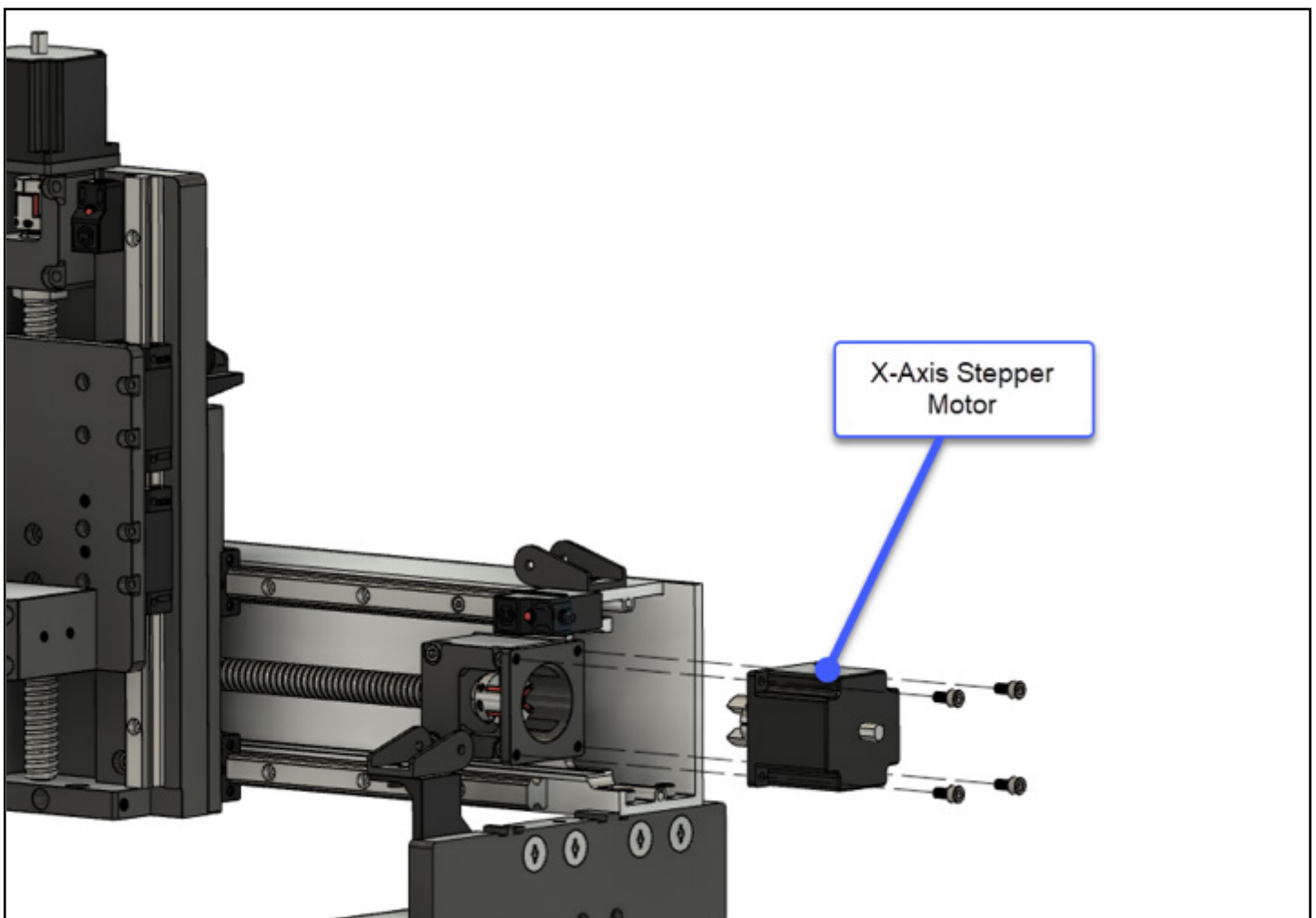

Figure 2-2

STEP 2

4. Press the couplers together until fully seated and the motor is flush with the motor mount. See **Fig. 2-4**.
5. Use a 4mm hex key and four (4) M5×10mm SHCS to secure the X-motor to the motor mount. Fully tighten.

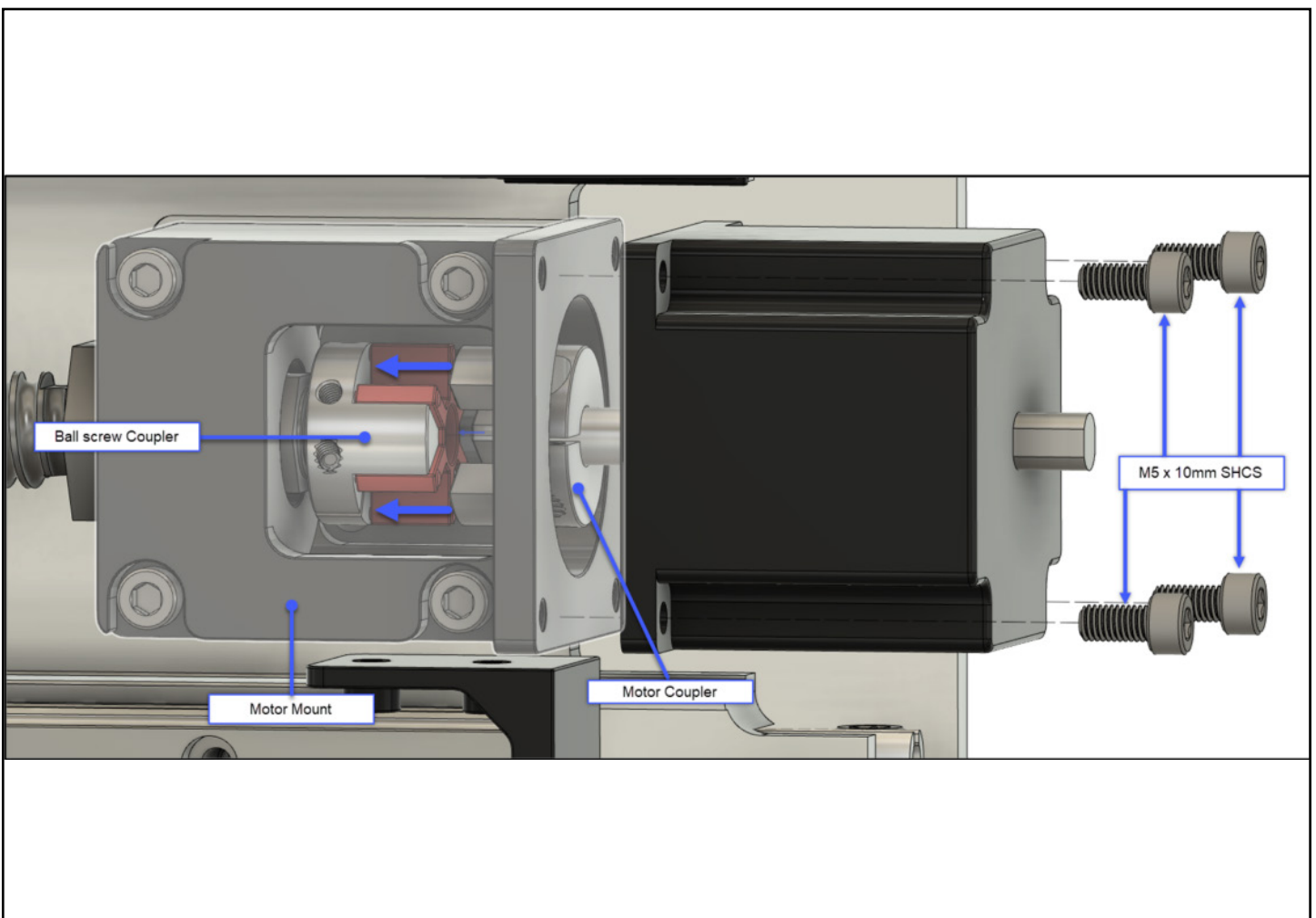

Figure 2-4

STEP 3

Hybrid Table

Items Needed for Step 3

| Description | Qty |
|--------------------------------|-----|
| Hybrid Extrusion | 10 |
| M6×10mm Flat Head Screws | 80 |
| MDF Strip | 10 |
| M6×20mm Socket Head Cap Screws | 40 |

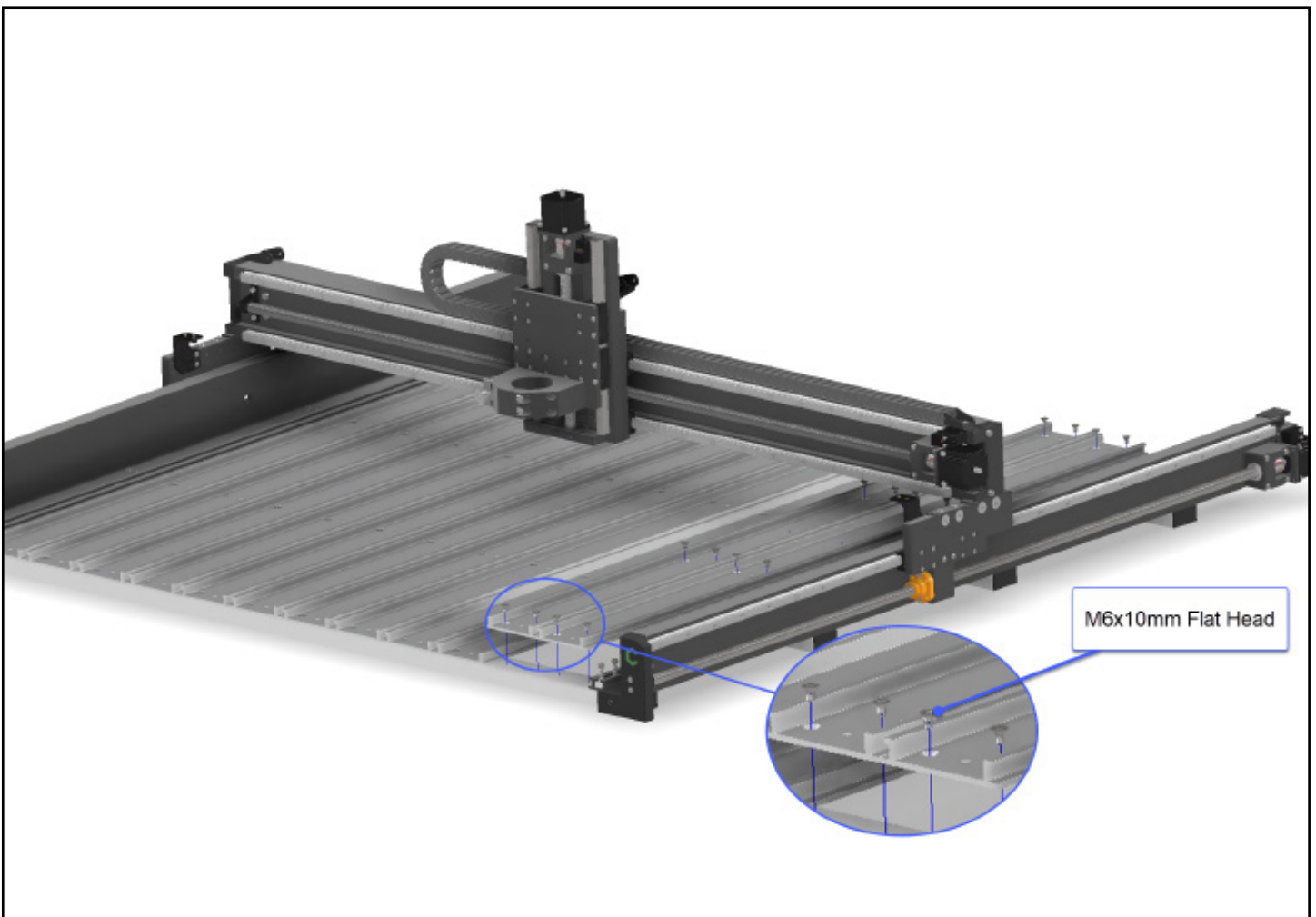

Figure 3-1

3.1 Install Extrusions

1. Locate the aluminum extrusions, MDF strips, and the small hardware box inside Box 2. The MDF strips are nested inside the extrusions.
2. Lay the ten (10) aluminum Hybrid Table extrusions across the baseframe, front to back.
3. Use a 4mm hex key and eight (8) M6×10mm FHS to loosely attach each extrusion. See **Fig. 3-1**.
 - a. Insert screws in order: front, back, center.
4. Fully tighten all screws to secure the extrusions.

NOTE: We do not recommend using power tools here; the risk of cross-threading is too high.

3.2 Install MDF Strips

1. Position the ten (10) MDF strips inside the Hybrid Table extrusions. See **Fig. 3-2**.
2. Use a 5mm hex key and four (4) M6×20mm SHCS to loosely attach each MDF strip.
 - a. Insert screws in order: front, back, center.
3. Fully tighten all screws to secure the MDF strips.

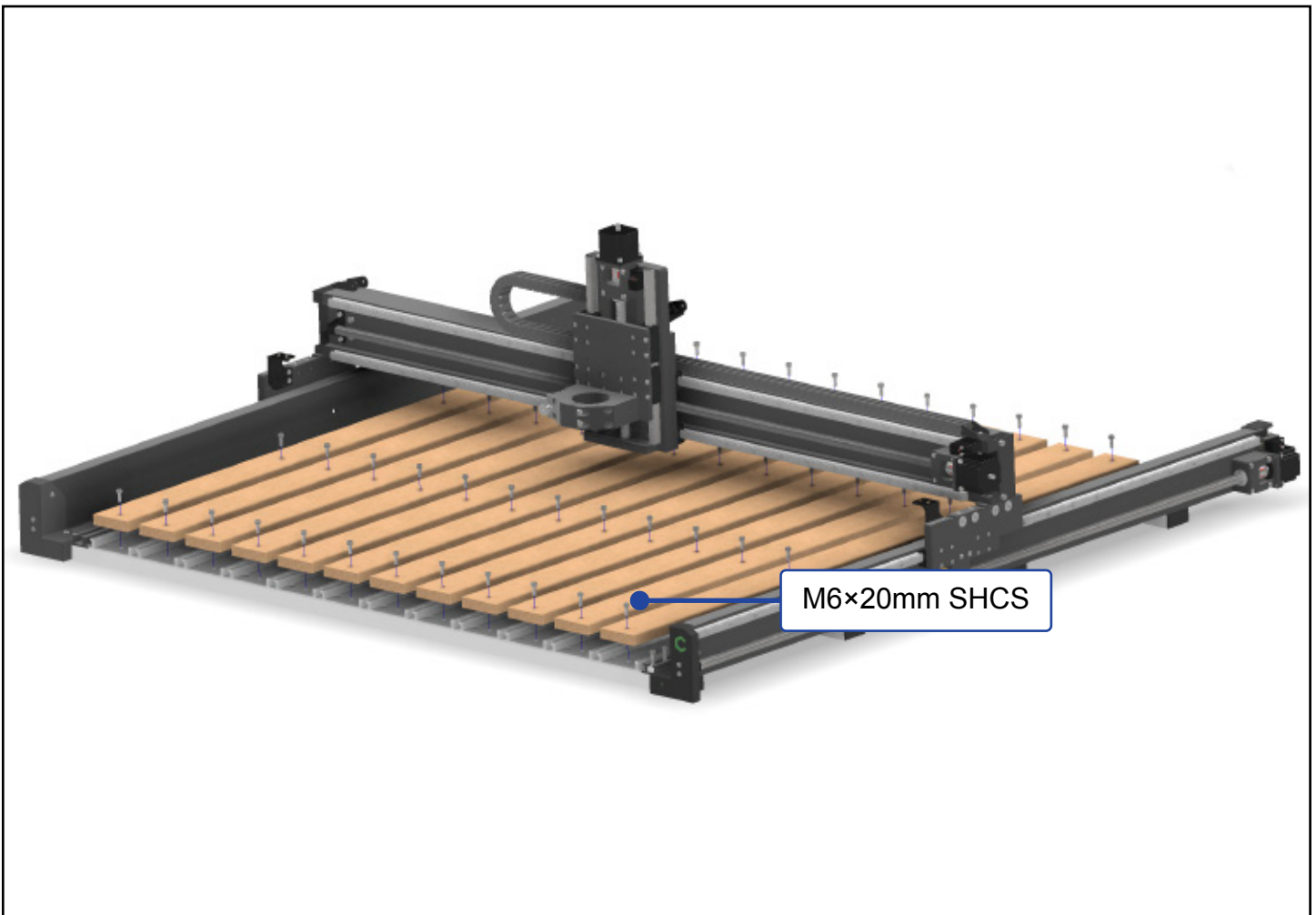

Figure 3-2

STEP 4

Wiring Harness

Items Needed in Step 4

| Description | Qty |
|--|-----|
| Wiring Harness | 1 |
| Drag Chain Hardware: M3×6mm Socket Head Cap Screws | 4 |
| Front Plate Extension Cable (3-pin Male to 4-pin Male) | 1 |
| Y-Right End Cap | 1 |
| Top End Cap Hardware: M6×30mm Socket Head Cap Screw | 1 |
| Bottom End Cap Hardware: M6×12mm Socket Head Cap Screw | 1 |
| Wire Keeper Hardware: M6×16mm Button Head Cap Screws | 4 |

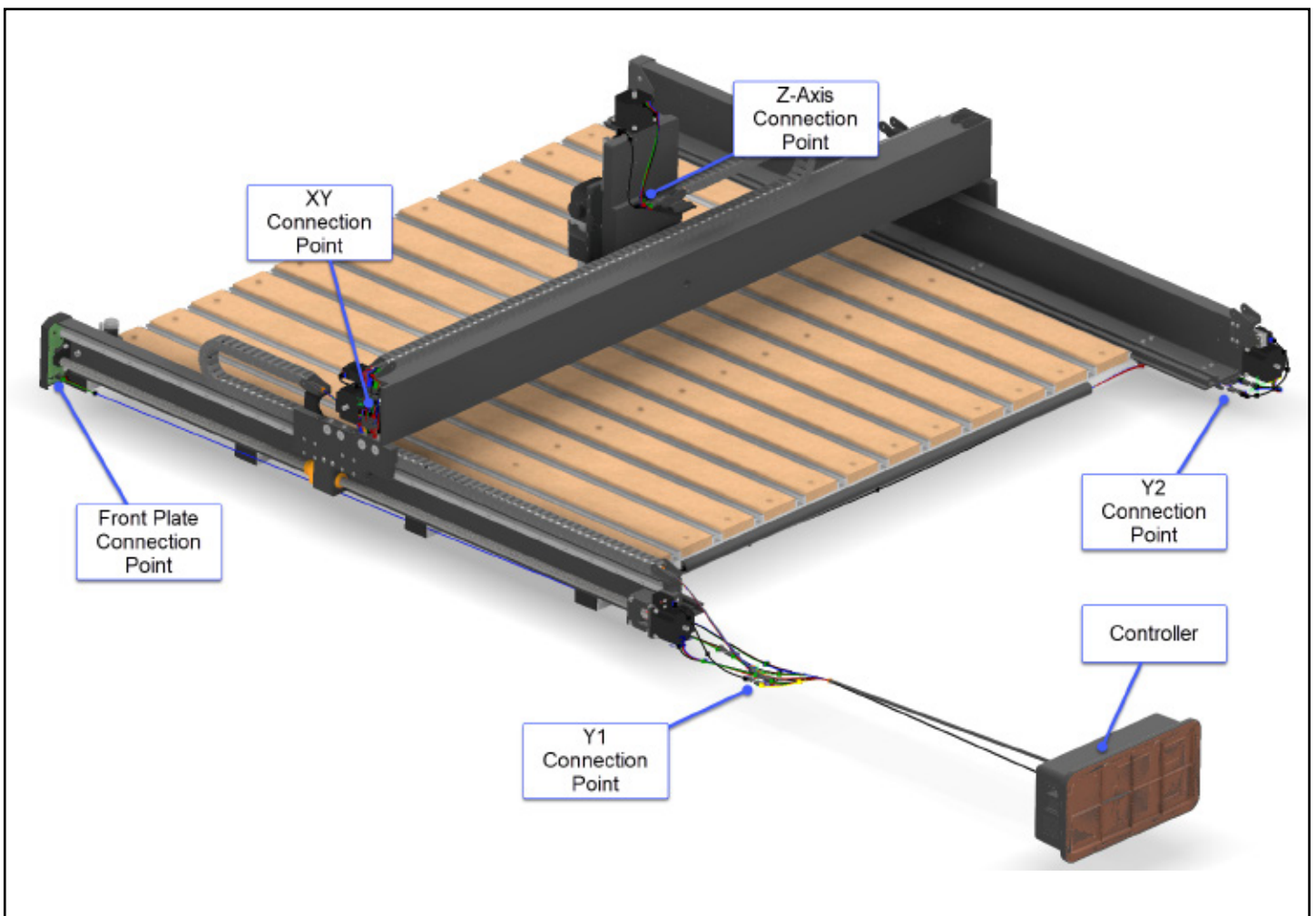

Figure 4-1

4.1 Install Wiring Harness

The wiring is pre-made, pre-tested, and is an exact fit for your machine. The wiring harness has several different branches: Z-Axis, X/Z/LED, front plate, Y-Left, Y-Right, and the controller. See **Fig. 4-1**.

1. Locate the wiring harness and drag chain hardware bag in the Wiring Harness box (inside the S5 Electronics box).
2. Unroll and lay the wiring harness across the baseframe, from front-to-back.
 - a. The five connectors and the grounding wire loop go to the front (the head).
 - b. The wiring harness trunk, the long cable bundle, goes to the back (the tail).
3. Lift the drag chain, slide it under the gantry, and place it on top of the Y-Right assembly.
4. Curl the head of the wiring harness up so that it rests on the bracket on the back of the Y-Right carriage plate. See **Fig. 4-2**.
5. Use a 2.5mm hex key and two (2) M3×6mm SHCS to secure the drag chain head to the bracket. Fully tighten. See **Fig. 4-2**.

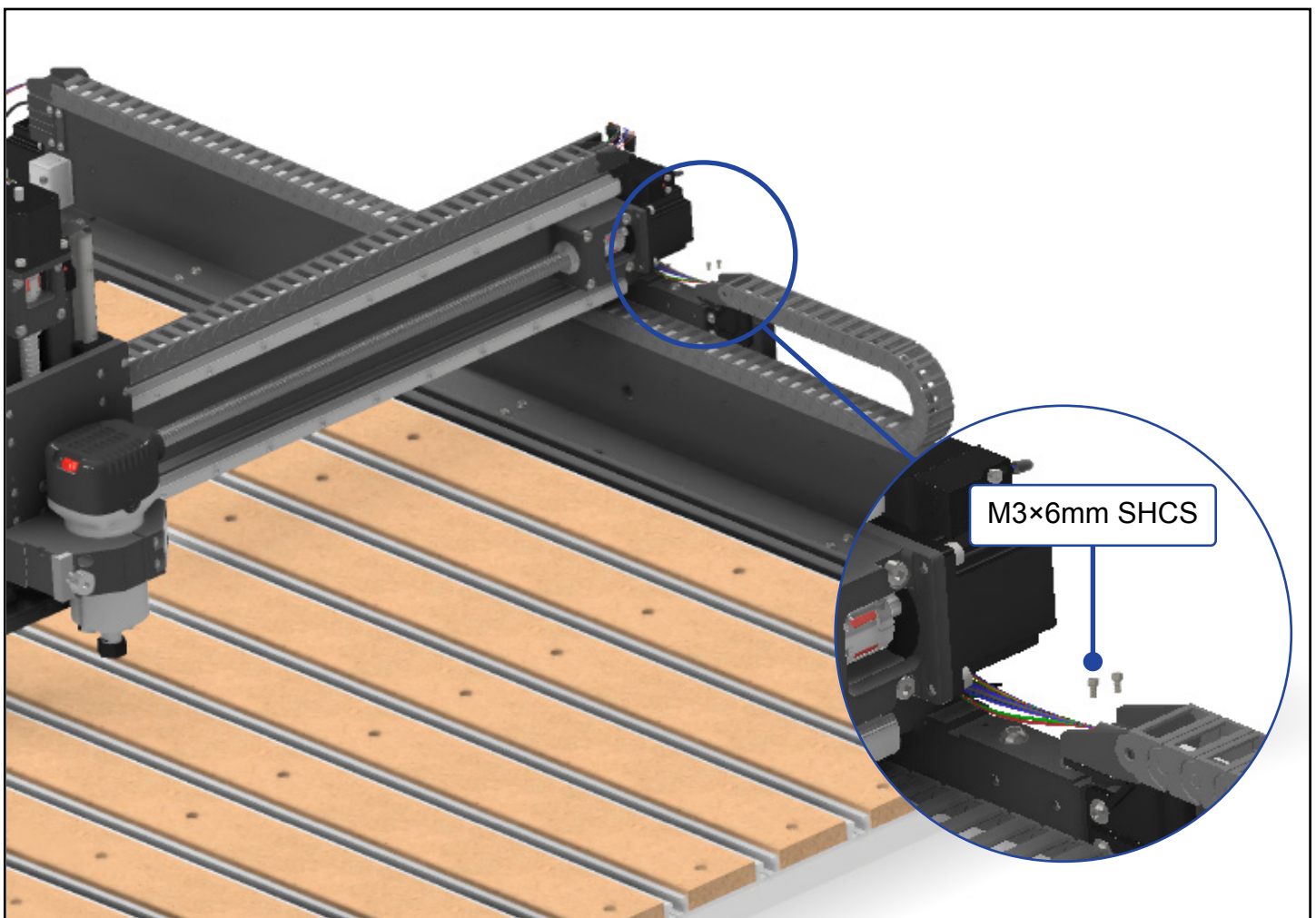

Figure 4-2

6. Use a 2.5mm hex key and two (2) M3×6mm SHCS to secure the tail of the drag chain at the rear of the Y-Right assembly. Fully tighten. See **Fig. 4-3**.
7. Put the drag chain hardware bag, with the remaining screws, back in the Wiring Harness box. You'll need them when we install the router drag chains in Step 5.

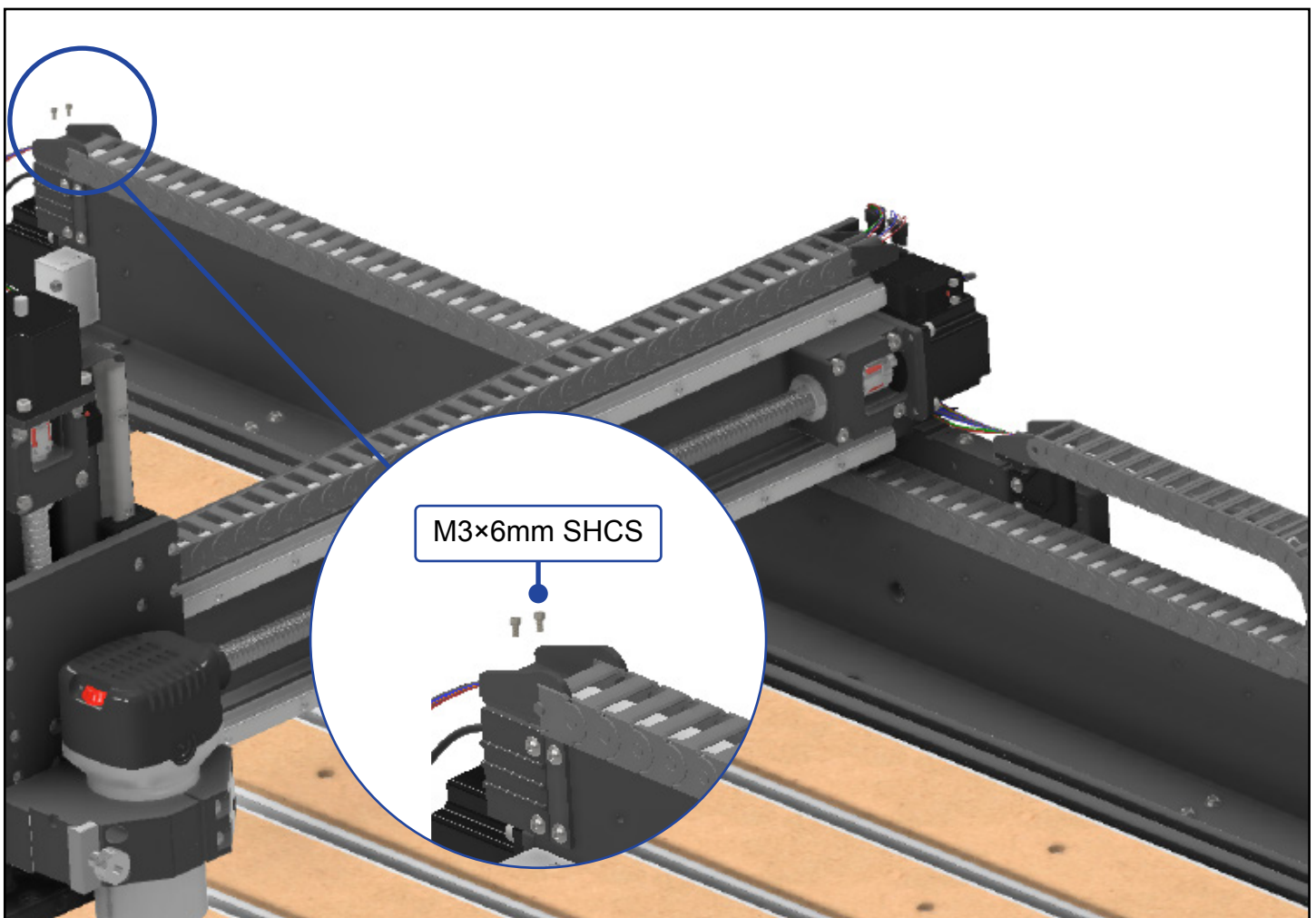

Figure 4-3

4.2 Install YL Wire Keeper

1. Move to the back of the machine.
2. Locate the long Y-Left wiring bundle extending from the wiring harness trunk. It has two plastic rectangular wire keepers attached.
3. Locate the Y-Left wire keeper at the end of the cables. “YL” is printed on the bottom side.
4. Slide the wire keeper under the back edge of the Y-Left assembly (right side when standing at the back of the machine). See **Fig. 4-4**.
 - a. The wires face up.
 - b. Align the screw holes in the wire keeper with those in the assembly.
5. Use a 4mm hex key and two (2) M6×16mm BHCS to attach the wire keeper to the Y-Left assembly. Fully tighten. See **Fig. 4-4**.
6. Open the cable track on the last baseframe member and slide the wires in, extending them all the way to Y-Right.
7. Snap the cover back in place to close the cable track.
 - a. Make sure all wires are completely in the track and that no wires are getting pinched.

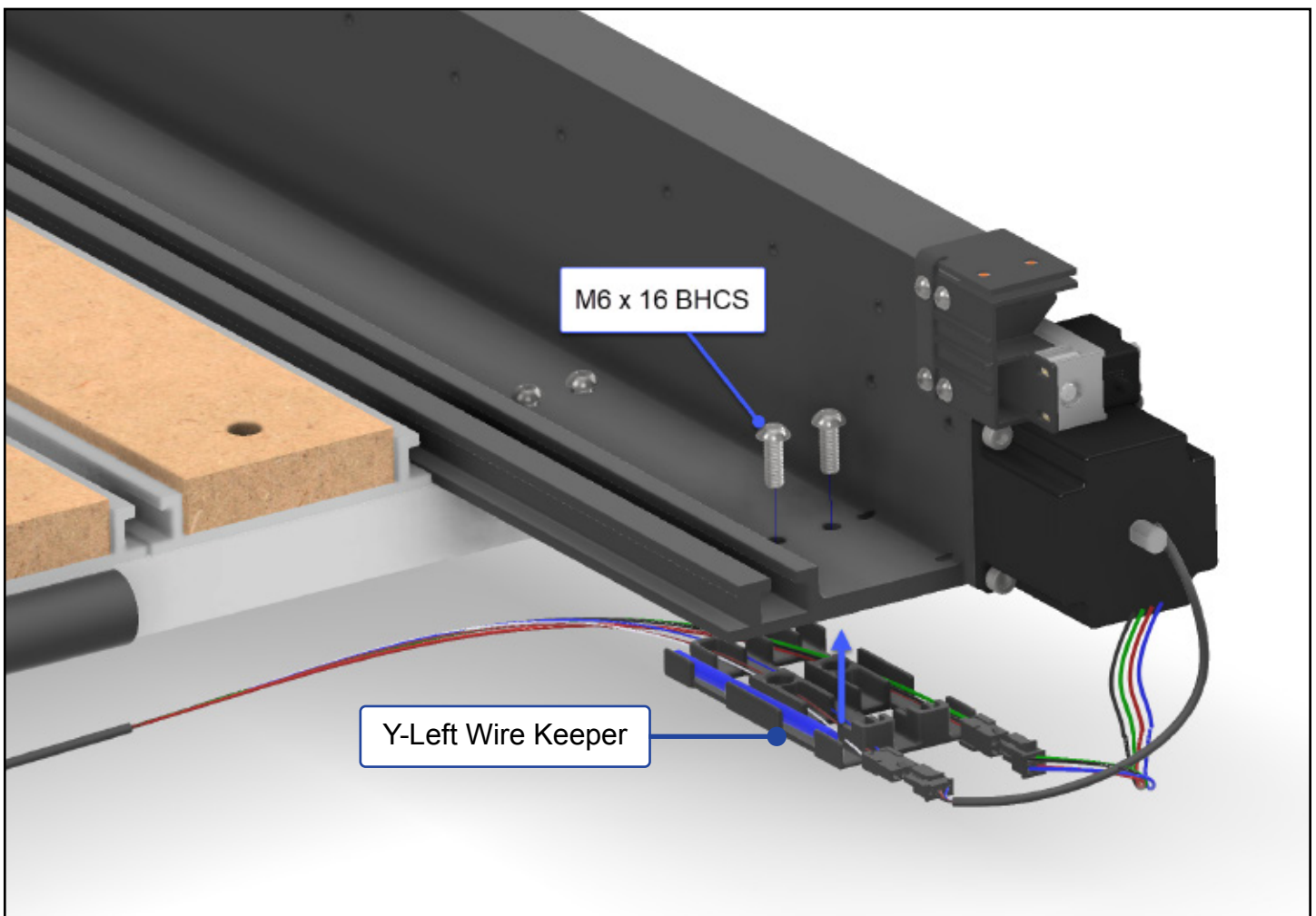

Figure 4-4

4.3 Connect Front Plate

1. Locate the front plate extension cable (3-pin to 4-pin) in the Wiring Harness box.
2. Plug the cable's 3-pin connector into the 3-pin connector on the back side of the front plate. See **Fig. 4-5**.
3. Moving backwards, keep tension on the cable as you snap each wire clip on the ends of the baseframe members over the cable.
4. Direct the end of the cable past the final baseframe member and under the end of the Y-Right assembly.
5. Plug the extension cable into the 4-pin, single row connector exiting the wiring harness at the back of the machine.

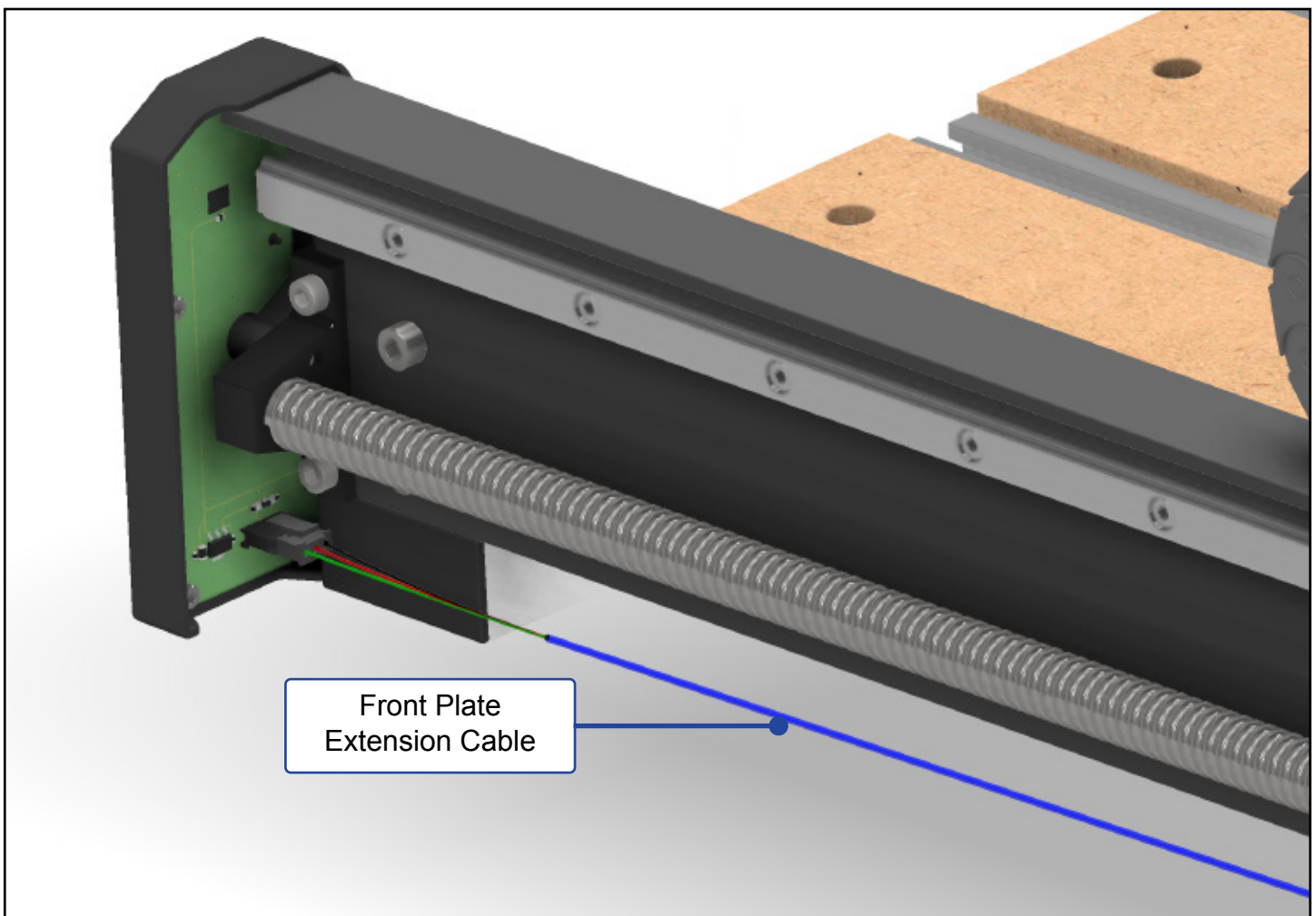

Figure 4-5

4.4 Install YR Wire Keeper

1. Locate the Y-Right wire keeper. It has “YR” printed on the bottom side.
2. Set the front plate extension cable into the wire keeper. See **Fig. 4-6**.
3. Slide the wire keeper under the back edge of the Y-Right assembly. See **Fig. 4-6**.
 - a. The wires face up.
 - b. Align the screw holes in the wire keeper with those in the assembly.
4. Use a 4mm hex key and two (2) M6×16mm BHCS to attach the wire keeper to the Y-Right assembly. Fully tighten.

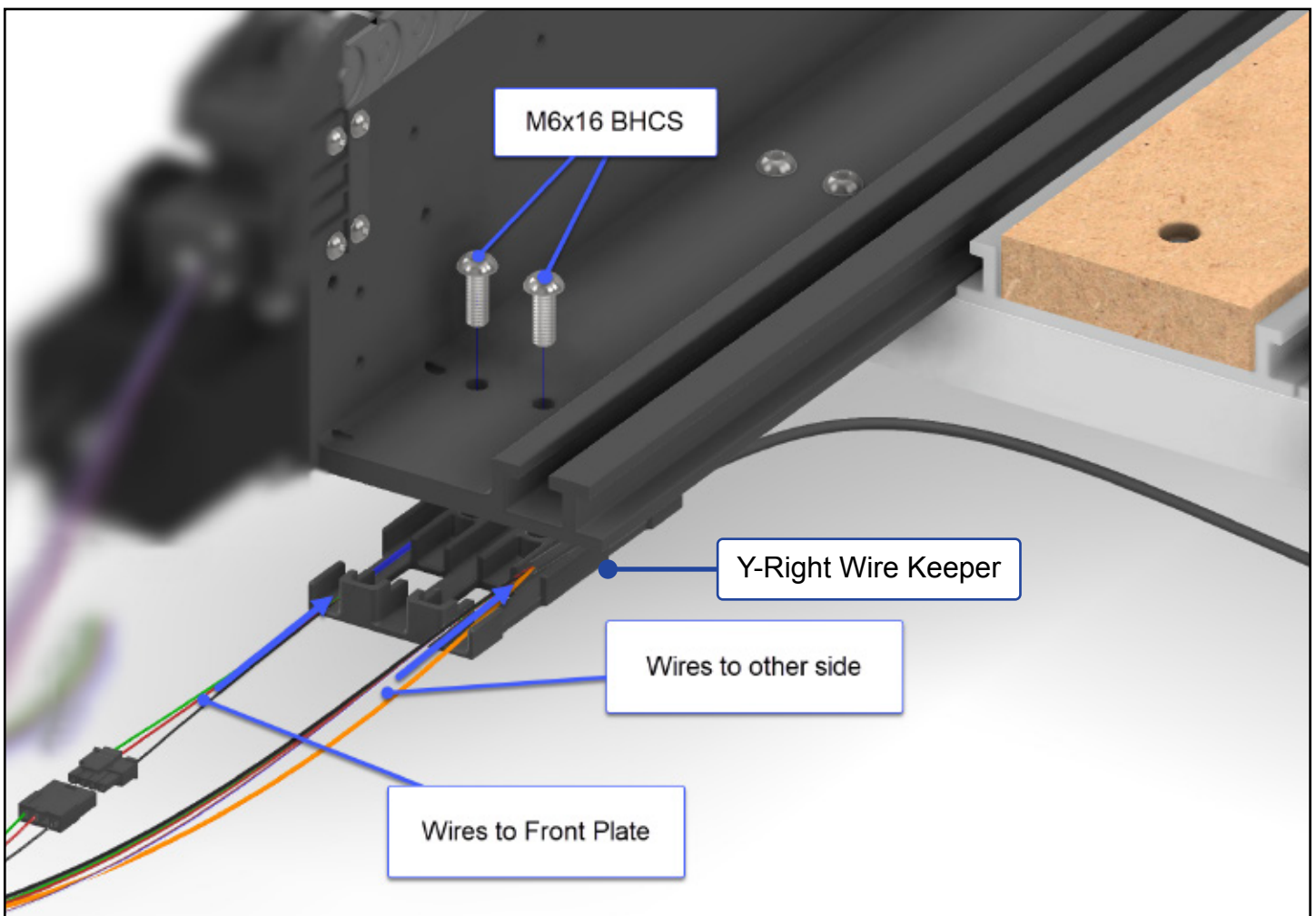

Figure 4-6

4.5 Attach Cables at Y-Right

NOTE: Connectors are polarized and will only connect one way. Do not force a connection. Be sure the connectors are properly oriented with the locking tabs aligned before plugging them in. See **Fig. 4-8**.

1. Move to the Y-Right side of the gantry.
 - a. Five cables exit the wiring harness head at Y-Right: LED, X-motor, Z-motor, Z-limit switch, and X-limit switch.
 - b. Each cable has a different connector type, so there is only one match for each connector.

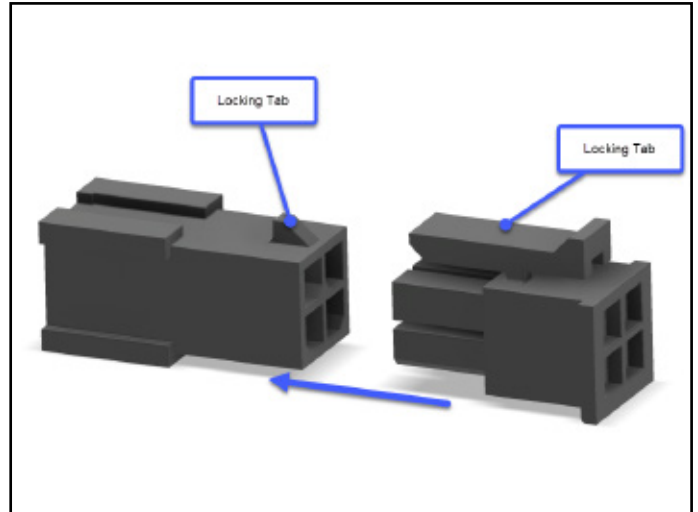

Figure 4-8

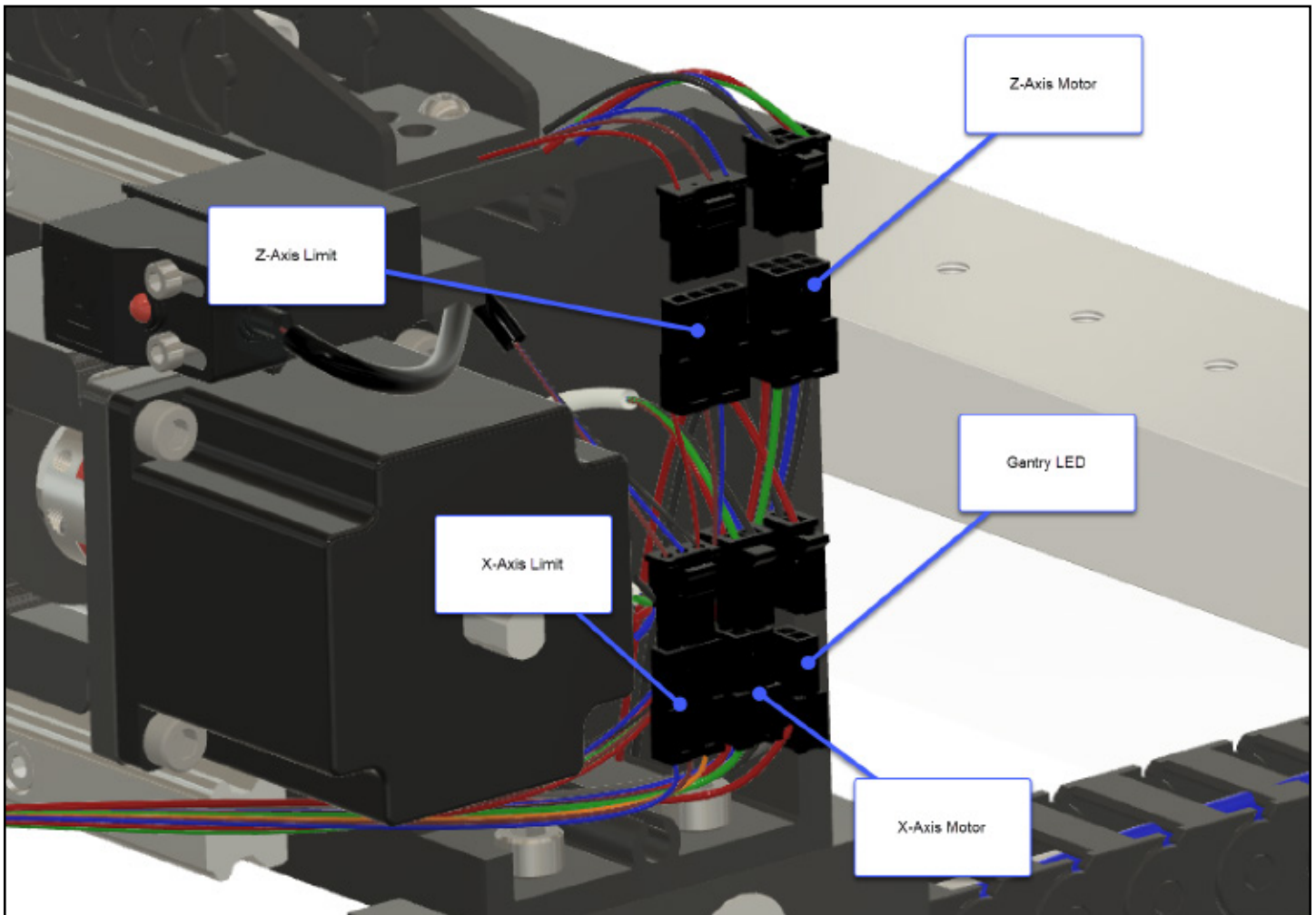

Figure 4-7

STEP 4

2. Connect the gantry LED. See **Figs. 4-7** and **4-9**.
 - a. LED connectors are 2-pin, dual-row (vertical).
 - b. The LED cable exits the end of the gantry.
 - c. Align the locking tabs for proper orientation.
3. Connect the X-Axis stepper motor.
 - a. X-motor connectors are 4-pin, dual-row.
 - b. Align the locking tabs for proper orientation.
4. Connect the X-Axis limit switch.
 - a. X-limit switch connectors are 3-pin, single-row.
 - b. Align the locking tabs for proper orientation.
5. Connect the Z-Axis stepper motor.
 - a. Z-motor connectors are 6-pin, dual-row.
 - b. Align the locking tabs for proper orientation.
6. Connect the Z-Axis limit switch.
 - a. Z-limit switch connectors are 4-pin, single-row.
 - b. Align the locking tabs for proper orientation.
7. Direct all five wires below the X-Axis motor mount, then tuck them into the open end of the gantry extrusion.

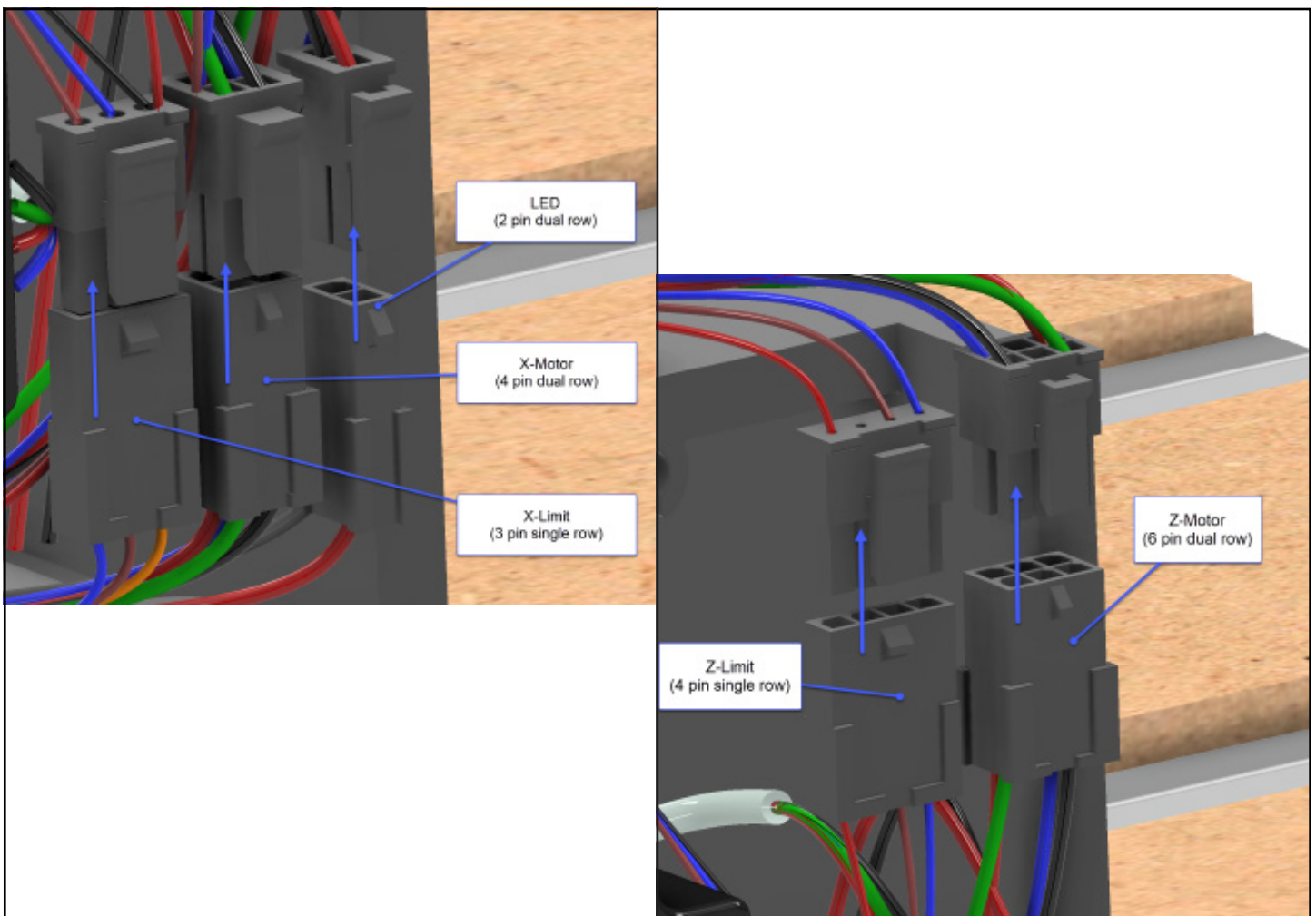

Figure 4-9

4.6 Install Y-Right End Cap

1. Gather the Y-Right end cap and hardware, one M6×30mm and one M6×12mm SHCS.
2. Make sure the wiring at Y-Right is tucked into the cavity in the extrusion.
3. Place the right end cap on the Y-Right end of the gantry extrusion. See **Fig. 4-10**.
 - a. The long straight edge goes to the back.
 - b. Be careful not to pinch the wires behind the end cap.
4. Use a 5mm hex key to insert one (1) M6×30mm SHCS through the top screw hole.
5. Locate the green and yellow grounding wire exiting the wiring harness at the head.
6. Place the loop at the end of the grounding wire onto the end of the M6×12mm SHCS.
7. Use a 5mm hex key to insert the M6×12mm SHCS through the bottom screw hole in the end cap. See **Figs. 4-10** and **Fig. 4-12**.

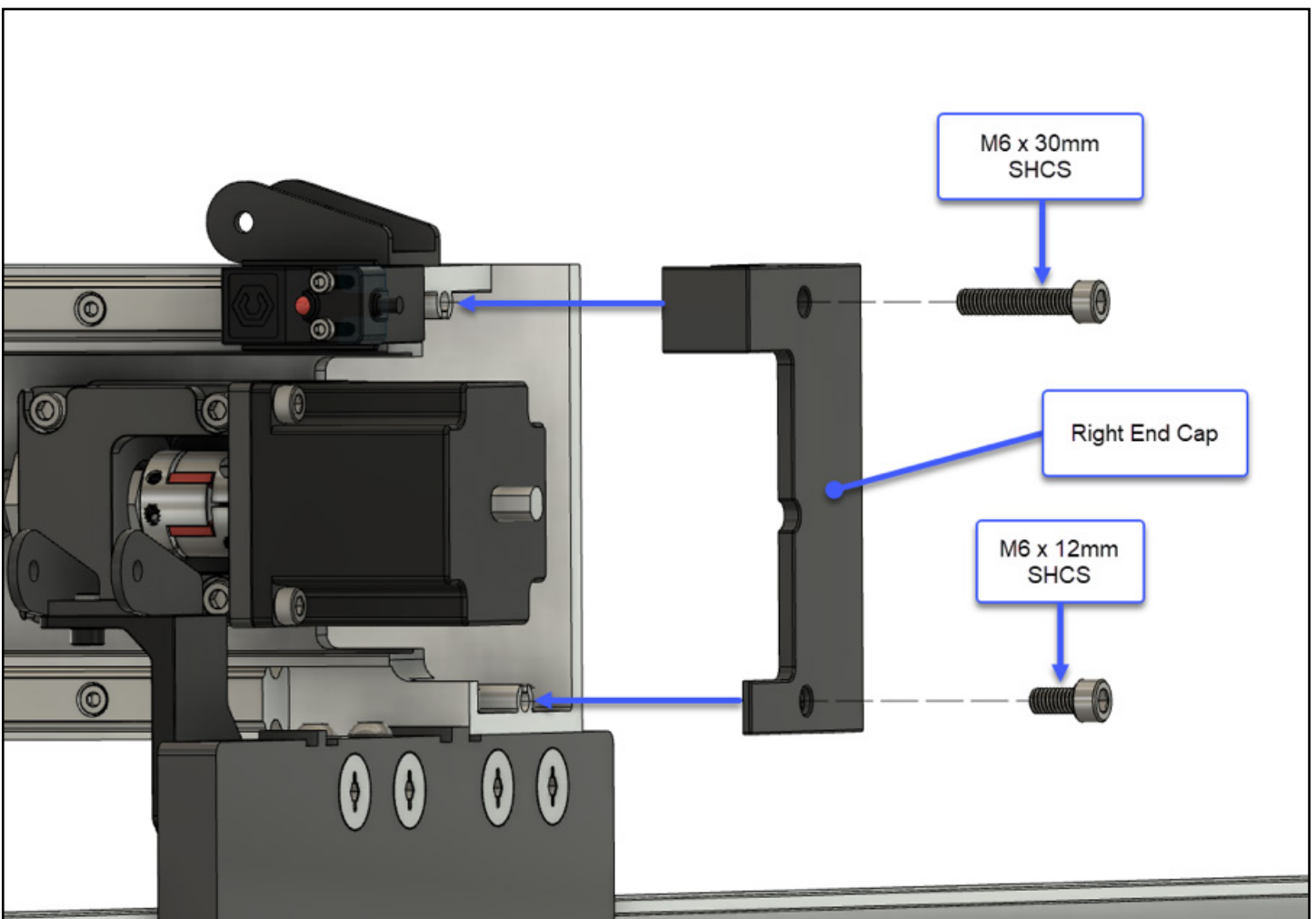

Figure 4-10

4.7 Connect Z-Axis Cables

1. At the back of the HDZ, connect the Z-Axis motor and Z-Axis limit switch cables. See **Fig. 4-11**.
 - a. Z-motor connectors are 4-pin, dual row.
 - b. Z-limit switch connectors are 3-pin, single row.

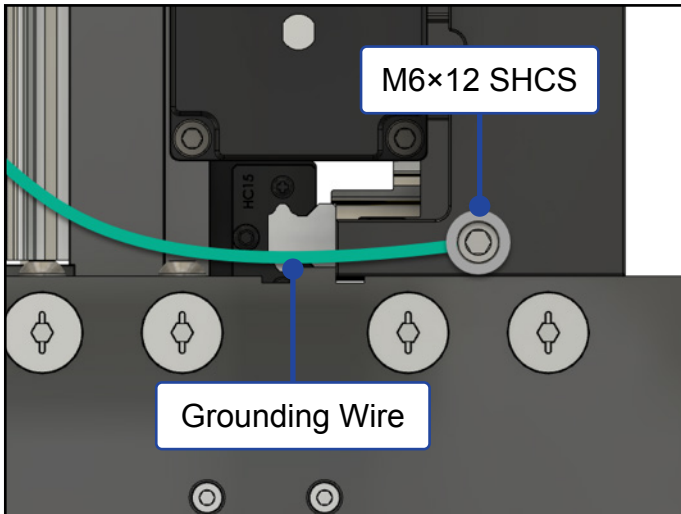

Figure 4-12

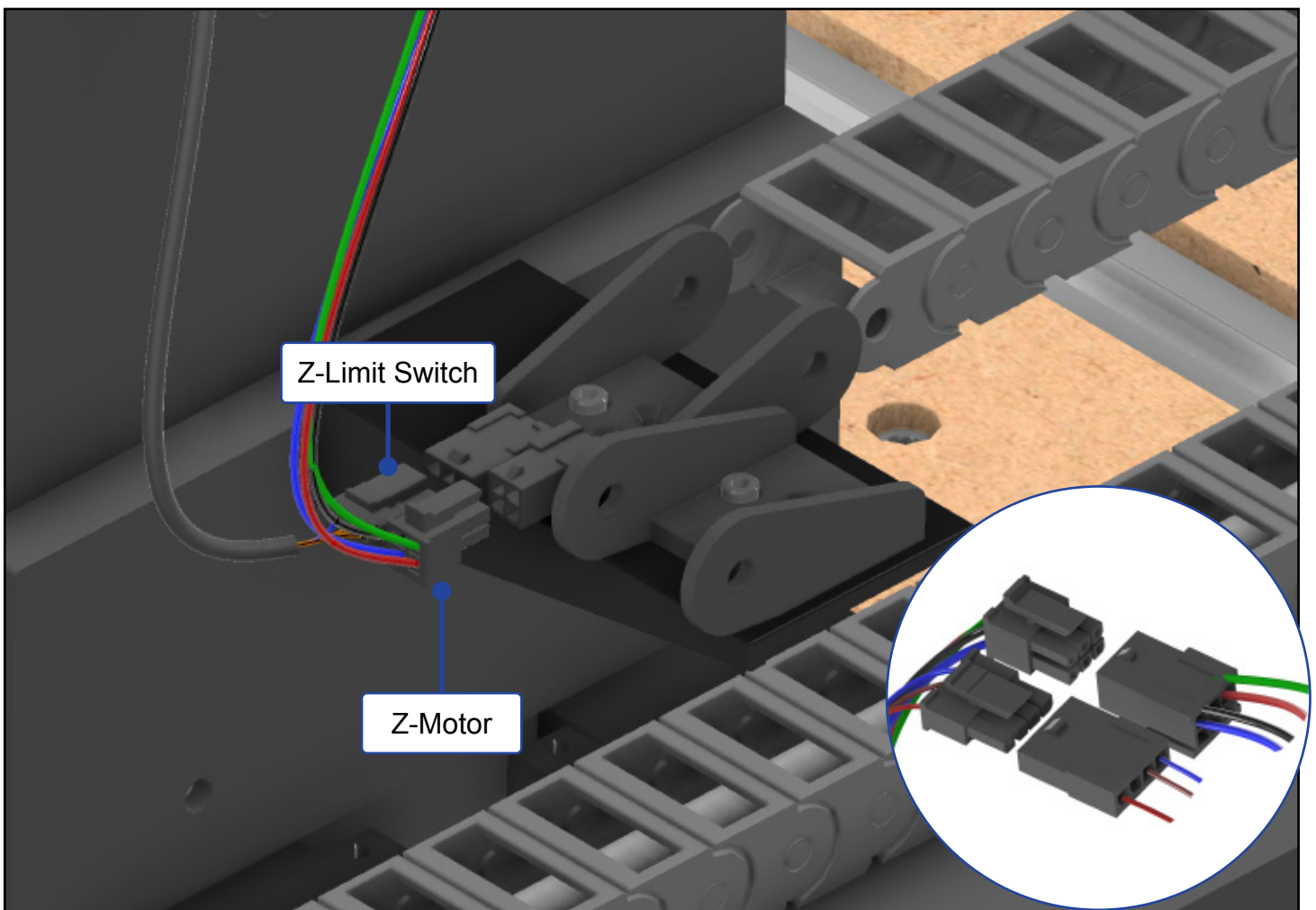

Figure 4-11

4.8 Connect Y-Left Motor and Limit Cables

1. Move to back of the machine at Y-Left (right side of the machine from the back).
2. Locate the two connectors, 4-pin Y-Left-motor and 3-pin Y-Left-limit switch, exiting from the Y-Left wire keeper.
3. Connect the Y-Left stepper motor. See **Fig. 4-13**.
 - a. YL-motor connectors are 4-pin, dual-row.
 - b. Align the locking tabs for proper orientation.
4. Connect the Y-Left limit switch. See **Fig. 4-13**.
 - a. YL-limit switch connectors are 3-pin, single-row.
 - b. Align the locking tabs for proper orientation.

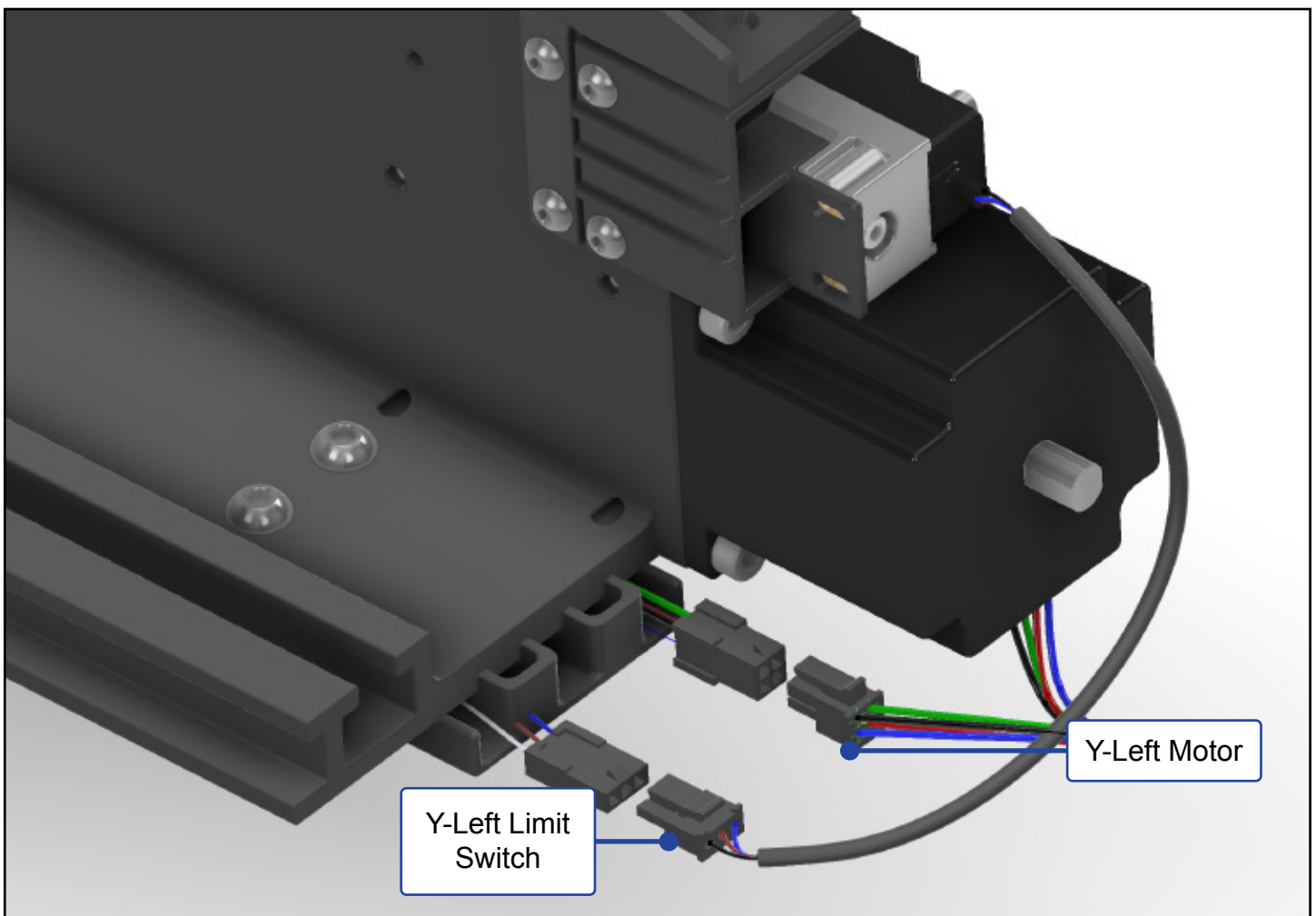

Figure 4-13

4.9 Connect Y-Right Motor and Limit Cables

1. Move to the Y-Right side of the machine.
2. Locate the two Y-Right cables (one 4-pin and one 3-pin) exiting the wiring harness trunk.
3. Connect the Y-Right stepper motor. See **Fig. 4-14**.
 - a. YR-motor connectors are 4-pin, dual-row.
 - b. Align the locking tabs for proper orientation.
4. Connect the Y-Right limit switch. See **Fig. 4-14**.
 - a. YR-limit switch connectors are 3-pin, single-row.
 - b. Align the locking tabs for proper orientation

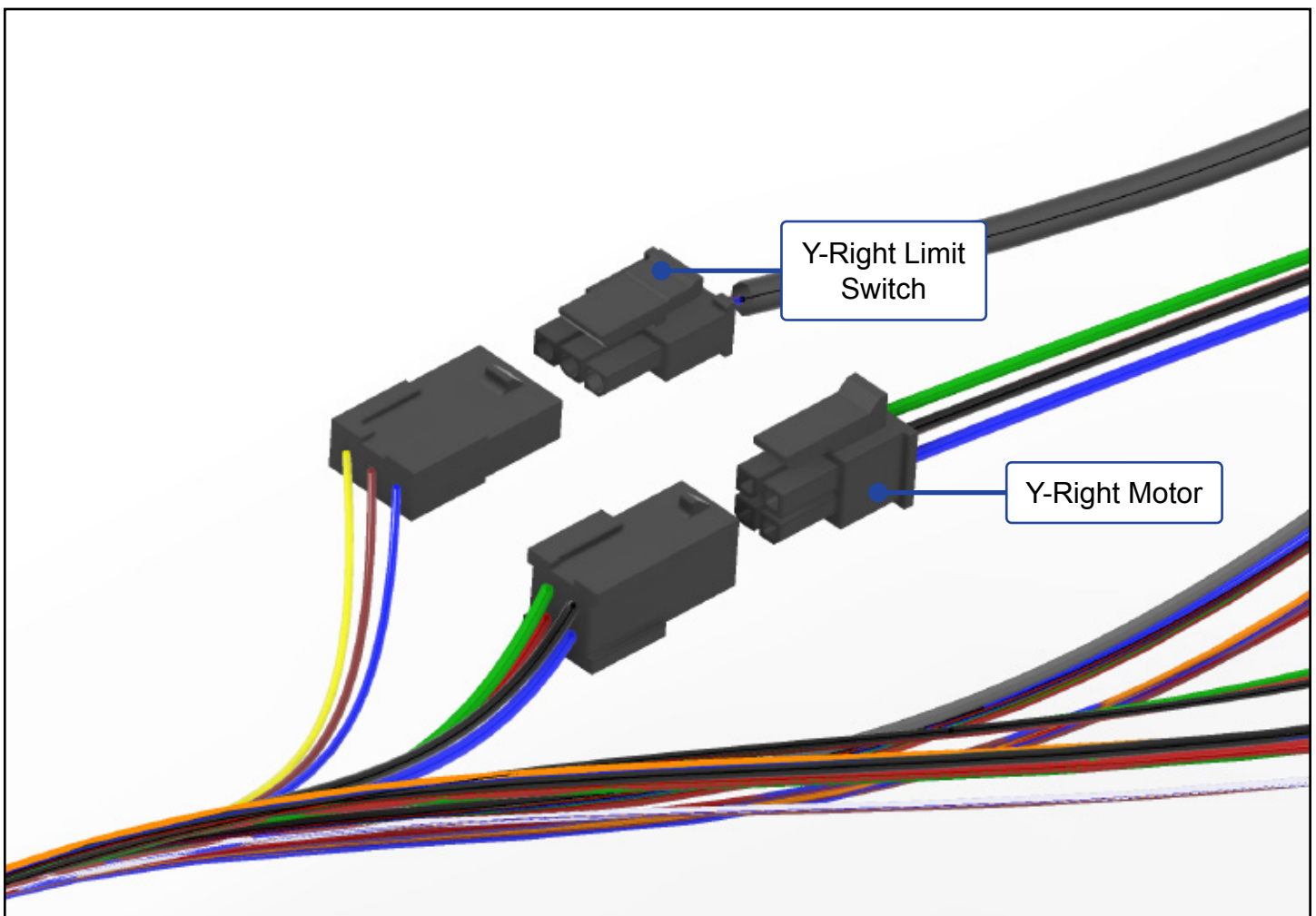

Figure 4-14

4.10 Install Grounding Block

1. Locate the grounding block and its hardware in the Grounding Block bag.
2. Position the grounding block on the inside of the Y-Right assembly, at the rear. See **Fig. 4-15**.
 - a. Six non-threaded holes face the rear.
 - b. Two threaded holes face up.
3. Use a 3mm hex key and two (2) M4×30mm BHCS to attach the grounding block to the inside of the Y-Right assembly. See **Fig. 4-15**.
4. Locate the green and yellow cable with the banana plug exiting the wiring harness.
5. Insert the banana plug into any of the six non-threaded holes on the rear face of the grounding block.

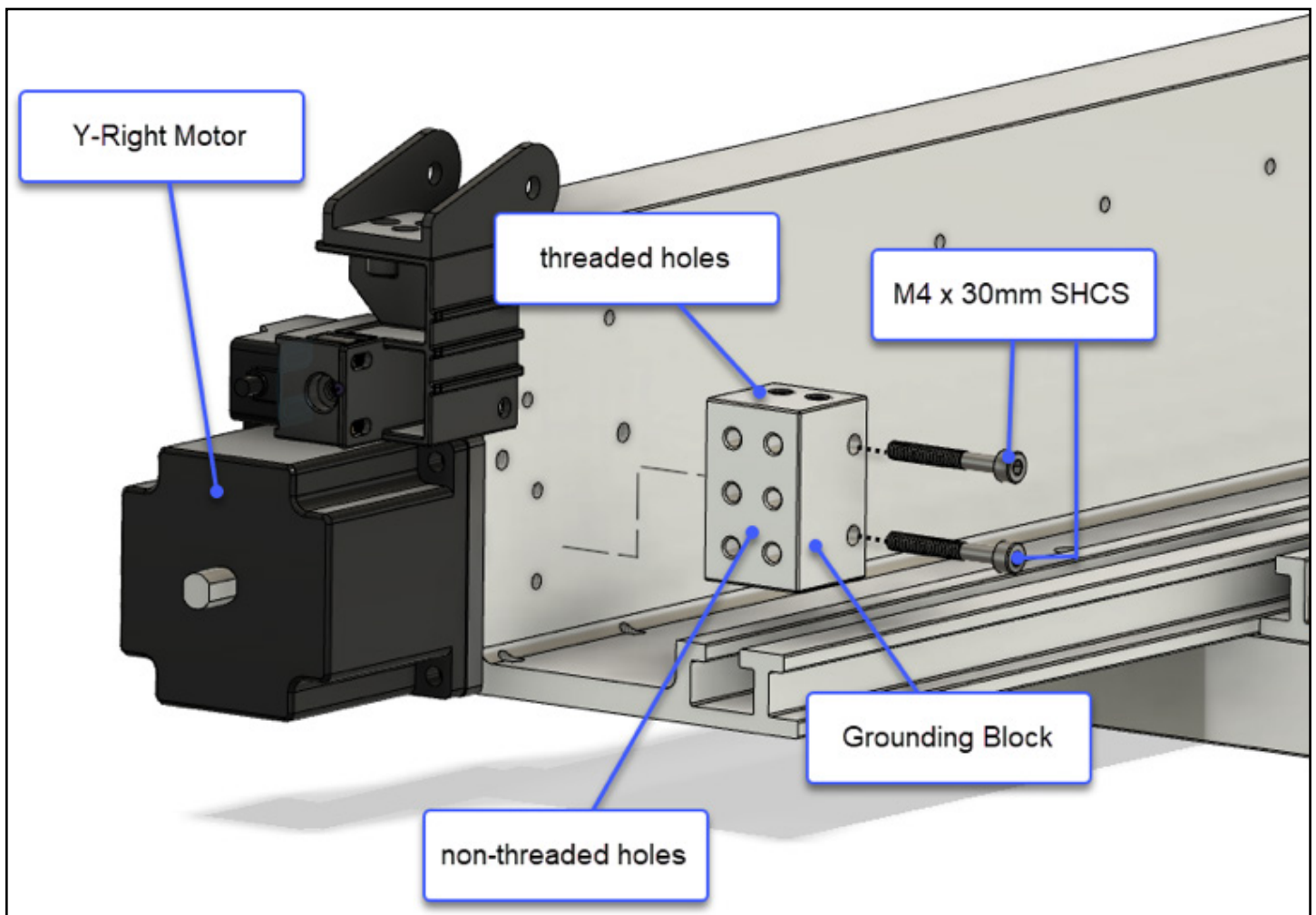

Figure 4-15

4.11 Connect Front Plate Extension

1. Locate the end of the front plate extension (4-pin, single-row) at the back of the machine at Y-Right.
2. Connect the extension cable to the 4-pin, single row connector exiting the wiring harness.
 - a. Align the locking tabs for proper orientation.

STEP 5

Spindle / Router

Items Needed in Step 5

| Description | Qty |
|--|-----|
| X- and Y-Axis Router Drag Chains | 2 |
| Router / Spindle (Optional Purchase) | 1 |
| Drag Chain Hardware: M3×6mm SHCS (6); M4×6mm BHCS (2) | 1 |
| Y-Left End Cap | 1 |
| Top End Cap Hardware: M6×30mm Socket Head Cap Screw | 1 |
| Bottom End Cap Hardware: M6×12mm Socket Head Cap Screw | 1 |

5.1 Preparing the Router Drag Chains

1. Locate the two empty router drag chains in the Wiring Harness box.
2. Lay the drag chains flat, hinge-side up, side by side on the baseframe. See **Fig. 5-1**.
 - a. The X-Axis router drag chain has two more links than the Y-Axis drag chain.
3. Use a large hex key to pry open the link hinges on both drag chains.
4. Use a small flathead screwdriver to pry the head link and tail link off each drag chain and set them aside.

5.2 Insert Power Cable

1. Place the router at the head end of the X-Axis (longer) drag chain.
2. Lay the router power cable in the X-Axis drag chain and close the first and last links to hold the cable in place. See **Fig. 5-1**.
3. Lay the cable in the Y-Axis (shorter) drag chain.
4. Close the first and last links of the Y-Axis drag chain to hold the cable in place.
5. Snap closed the remaining links in both drag chains.
6. Snap the head and tail links back onto both drag chains.

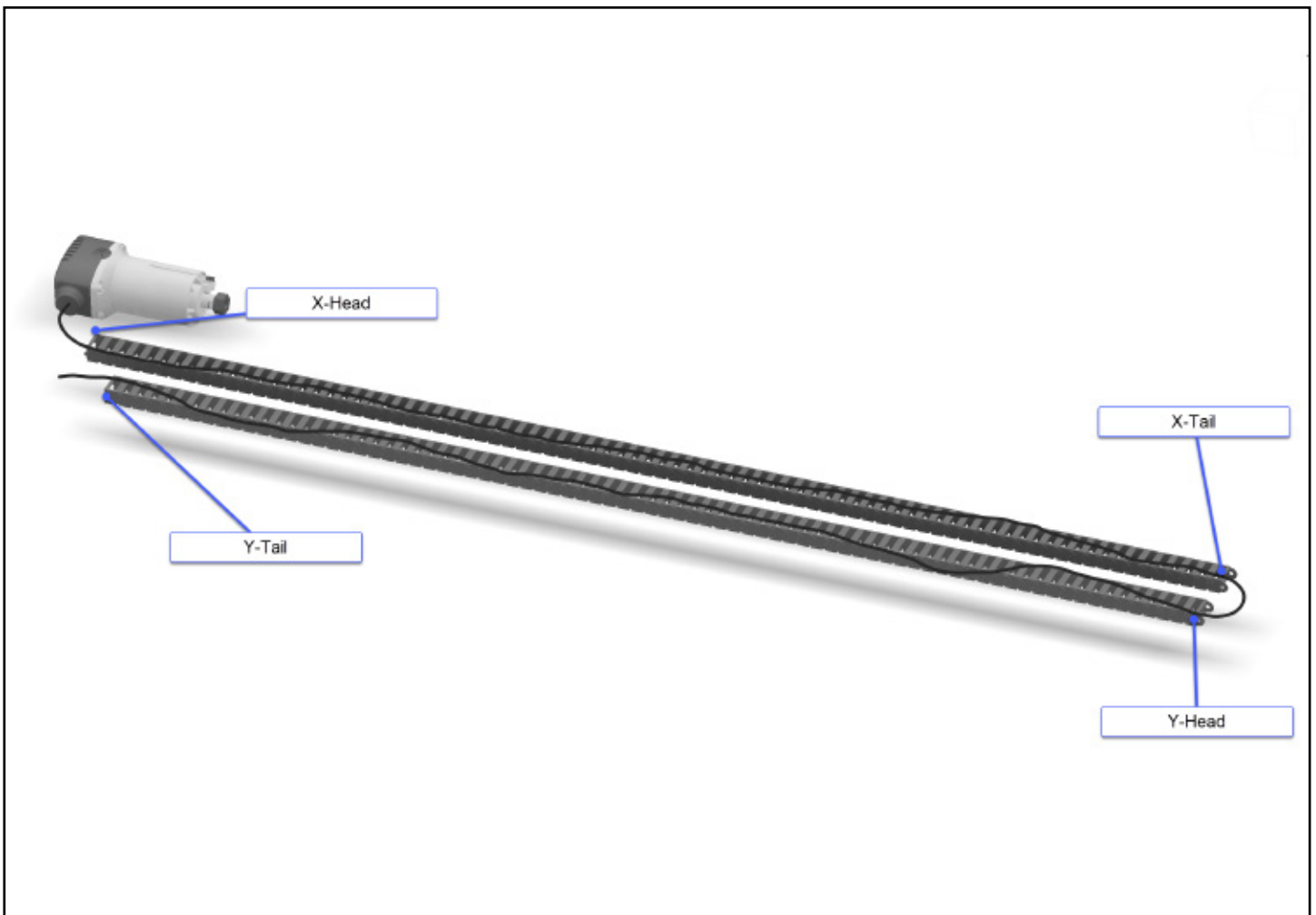

Figure 5-1

5.3 Install the Drag Chains

NOTE: When installing the drag chains, if a head or tail link is upside down, simply pry it off with a small screwdriver and reattach it, flat side to the rail.

1. Lift the drag chains and router and move them to the front of the machine.
2. Insert the router/spindle as far as it will go into the spindle mount on the front of the HDZ.
3. Lift the X-Axis (longer) drag chain over the HDZ and set it on top of the gantry. See **Fig. 5-2**.
4. Lift the Y-Axis (shorter) drag chain and set it onto the Y-Left assembly (it slides under the gantry). See **Fig. 5-3**.
5. Use a 2.5mm hex key and two (2) M3×6mm SHCS to secure the X-Axis (longer) drag chain head to the bracket on the back of the HDZ. Fully tighten.
6. Use a 2.5mm hex key and two (2) M4×6mm BHCS to secure the X-Axis drag chain tail to the Y-Left end of the gantry. Fully tighten.
7. Use a 2.5mm hex key and two (2) M3×6mm SHCS to secure the Y-Axis (shorter) drag chain head to the Y-Left carriage. Fully tighten.
8. Use a 2.5mm hex key and two (2) M3×6mm SHCS to secure the Y-Axis drag chain tail to the Y-Left assembly. Fully tighten.

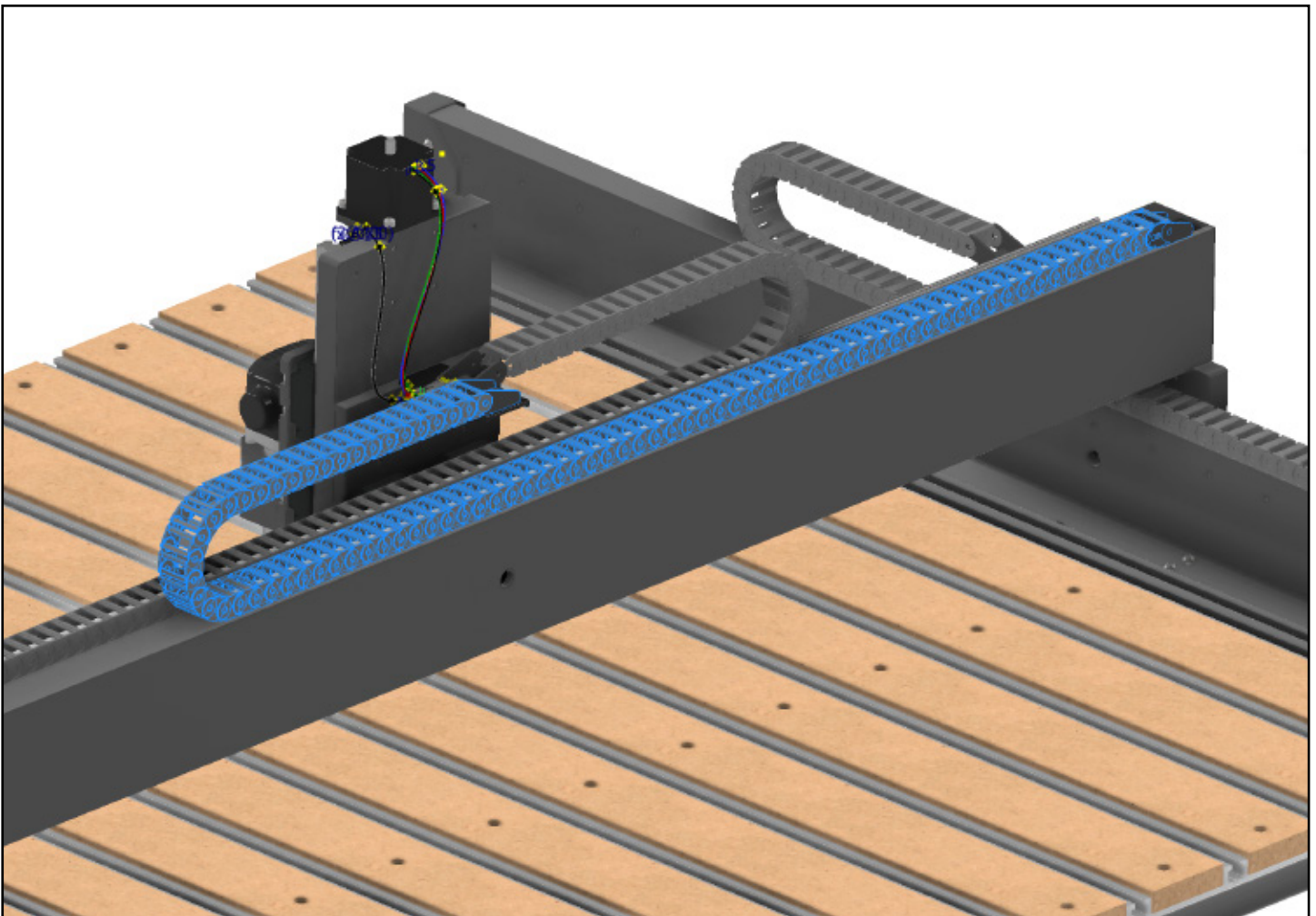

Figure 5-2

5.4 Secure Router & Cable

1. Orient the router in the spindle mount so that the power cable extends toward Y-Left.
2. Use a 5mm hex key to tighten the four (4) M6 screws, securing the router in the spindle mount.
3. Push the HDZ down to the bottom of travel.
 - a. Make sure there is enough power cable to allow the HDZ to move freely and to prevent binding during travel.
4. Use a zip tie to secure the router power cable to the head end of the X-Axis router drag chain.
5. Use a zip tie to secure the router power cable to the tail end of the X-Axis router drag chain.

5.5 Install Y-Left End Cap

1. Gather the Y-Left end cap and hardware, one M6×30mm SHCS and one M6×12mm SHCS.
2. Route the router power cable down over the edge of the gantry.
3. Place the end cap over the Y-Left end of the gantry and the power cable.
 - a. The long straight edge goes to the back.
4. Use a 5mm hex key to insert one (1) M6×30mm SHCS through the top screw hole and one (1) M6×12mm SHCS through the bottom screw hole.

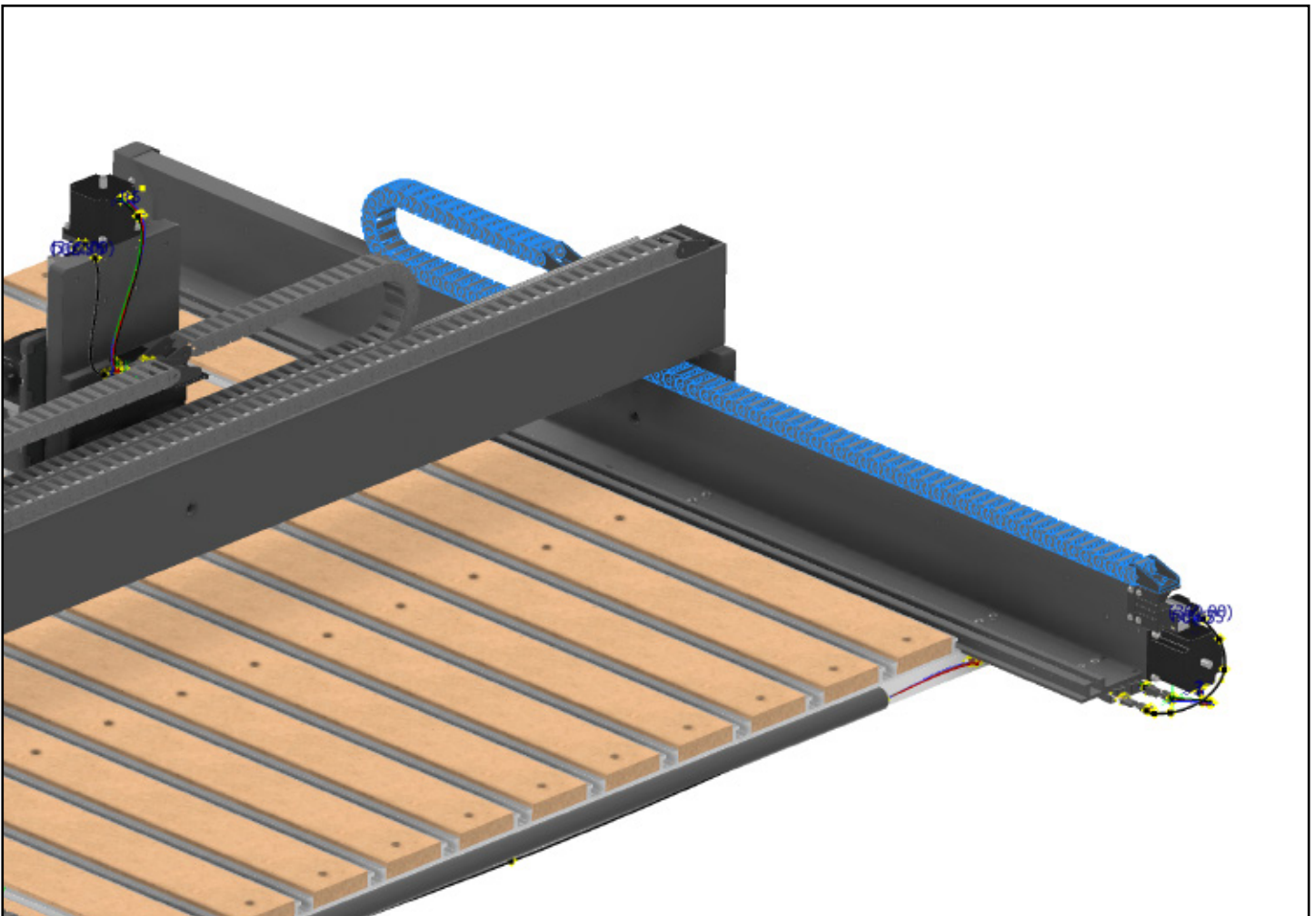

Figure 5-3

STEP 6

Controller and BitSetter

Items Needed in Step 6

| Description | Qty |
|--|-----|
| Controller | 1 |
| Power Pendant | 1 |
| Power Pendant Extension Cable (8-pin Male to 6-pin Male) | 1 |
| USB Cable | 1 |
| 3-Prong Controller Power Cable | 1 |
| BitSetter | 1 |
| BitSetter Hardware: M6×30mm (2) and Teez Nuts (2) | 4 |
| BitSetter Extension Cable (3-pin Male to 3-pin Male) | 1 |

6.1 Connect the Controller

1. Locate the Controller box, Power Pendant box, and USB cable in the S5 Electronics box.
2. Plug the 18-pin motor wiring bundle connector into the larger 18-pin “MOTORS” port on the controller. See **Fig. 6-1**.
3. Plug the 22-pin limit switch wiring bundle connector into the smaller 22-pin “SWITCHES” port on the controller. See **Fig. 6-1**.
4. Plug the 8-pin end of the power pendant cable into the port labeled “POWER PENDANT” on the controller.
5. Plug the 6-pin end of the power pendant cable into the power pendant.
- a. Align the locking tabs for proper orientation.
6. Plug the USB cable into the port labeled “USB”.
7. Plug the 3-prong power cable into the power jack on the side of the controller.

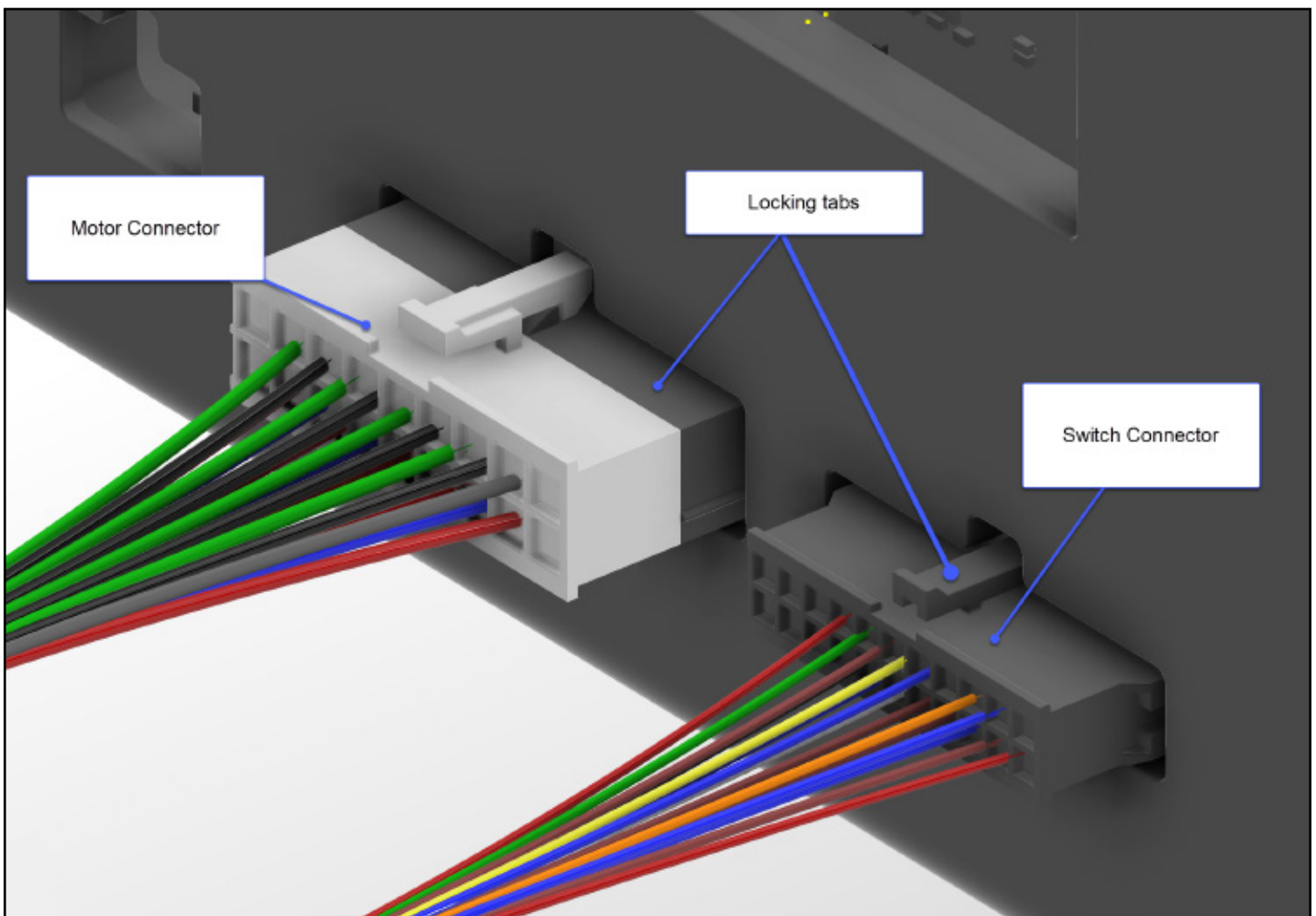

Figure 6-1

6.2 Install the BitSetter

1. Locate the BitSetter box in the S5 Electronics box.
2. Slide the two (2) Teez Nuts into the T-track slot integrated into the Y-Right assembly. See **Fig. 6-2**.
3. Position the BitSetter over the Teez Nuts.
 - a. The 3-pin port on the base faces to the right.
4. Use a 5mm hex key to loosely insert two (2) M6×30mm SHCS through the top of the BitSetter and into the Teez Nuts. See **Fig. 6-3**.
5. Slide the BitSetter close to the front edge of the baseframe. Fully tighten the SHCS.
6. Plug the short 3-pin BitSetter extension cable into the 3-pin port on the inside edge of the front-right endplate. See **Figs. 6-2** and **6-3**.
7. Plug the other end of the 3-pin extension cable into the 3-pin port on the BitSetter. See **Fig. 6-3**.

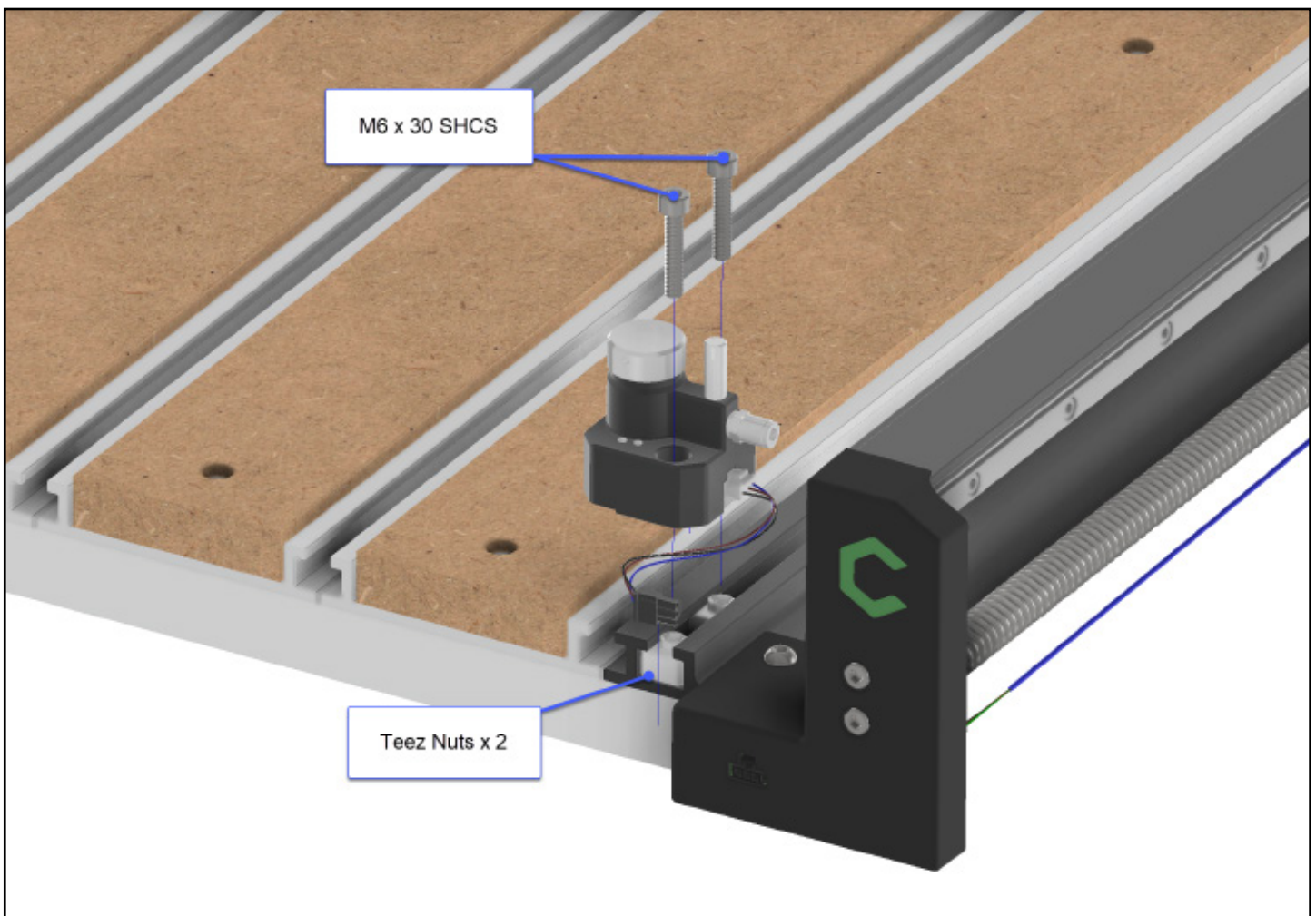

Figure 6-2

6.3 Tidy Up

1. Locate the zip ties and self-adhesive cable ties in the Open Me First box.
2. Use a self adhesive cable tie and a zip tie to tidy the Y-Left cables at the back of the machine.
3. Readjust the reusable velcro strapping attached to wiring harness trunk, as needed, to tidy the wiring harness cables.

IMPORTANT: Before homing your machine, you **MUST** update your machine configuration settings. See the Shapeoko 5 Pro Getting Started Guide for detailed instructions.

Congratulations, the Shapeoko 5 Pro assembly is complete!

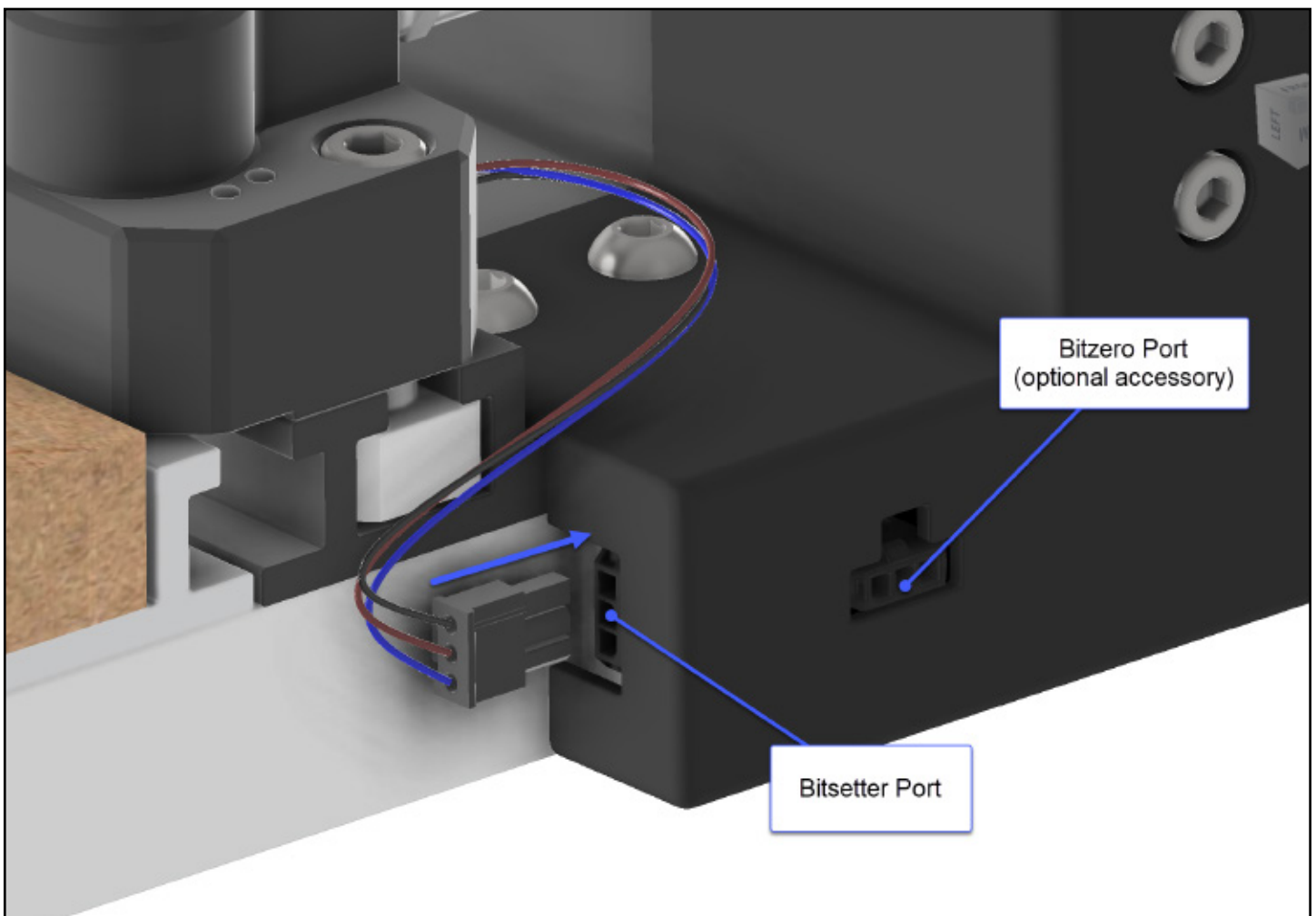

Figure 6-3



Carbide 3D

3630 Skypark Drive
Torrance, CA 90505

310-504-3637
support@carbide3d.com

 facebook.com/carbide3d
 instagram.com/carbide3d